

## VERY LOW DROP 1A REGULATOR

- LOW DROPOUT VOLTAGE (450mV Typ. at 1A)
- VERY LOW QUIESCENT CURRENT
- THERMAL SHUTDOWN
- SHORT CIRCUIT PROTECTION
- REVERSE POLARITY PROTECTION

### DESCRIPTION

The L4941 is a three terminal 5V positive regulators available in TO-220, TO-220FP and D<sup>2</sup>PAK packages, making it useful in a wide range of industrial and consumer applications. Thanks to its very low input/output voltage drop, these devices are particularly suitable for battery powered equipments, reducing consumption and prolonging battery life. It employs internal current limiting, antisaturation circuit, thermal shut-down and safe area protection.

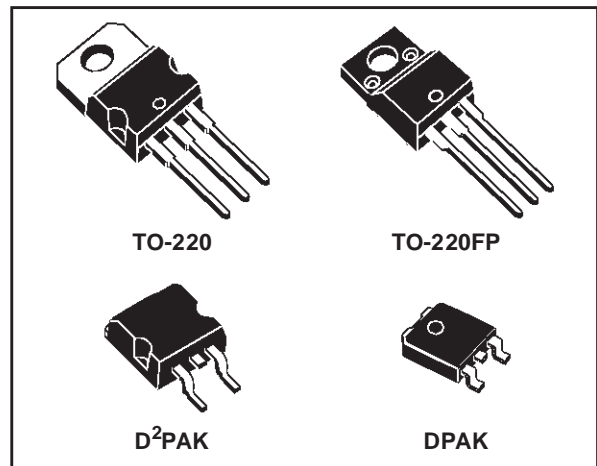

### BLOCK DIAGRAM

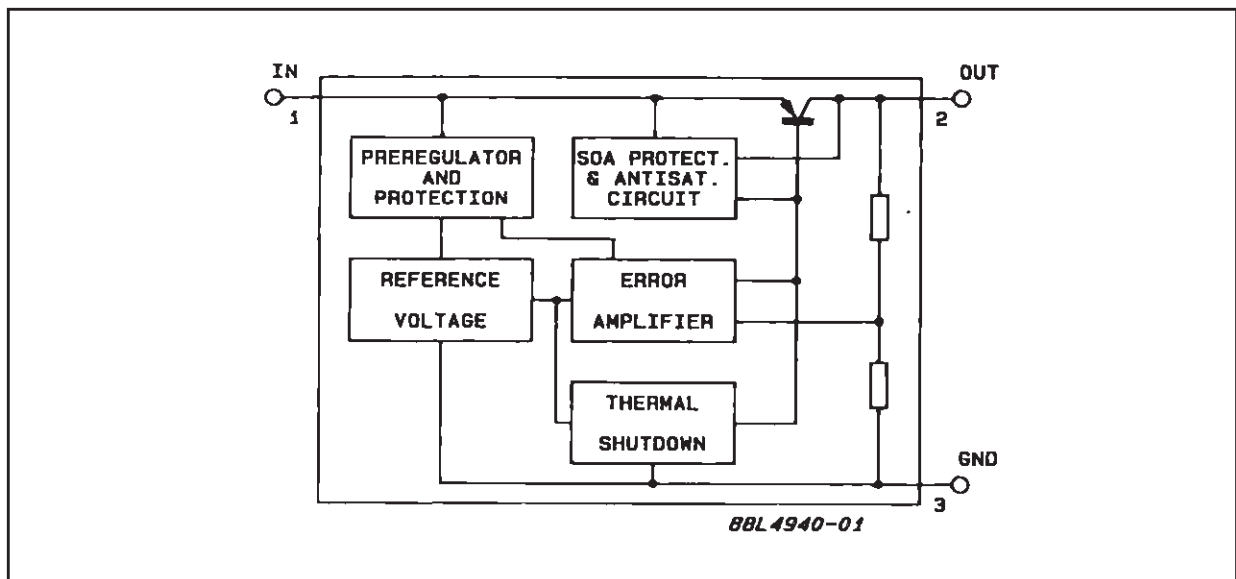

**ABSOLUTE MAXIMUM RATINGS**

Symbol	Parameter	Value	Unit
$V_I$	Forward Input Voltage	30	V
$V_{IR}$	Reverse Input Voltage ( $R_O=100\Omega$ )	-15	V
$I_O$	Output Current	Internally Limited	mA
$P_D$	Power Dissipation	Internally Limited	mW
$T_{stg}$	Storage Temperature Range	-40 to +150	°C
$T_{op}$	Operating Junction Temperature Range	-40 to +150	°C

Absolute Maximum Ratings are those values beyond which damage to the device may occur. Functional operation under these condition is not implied.

**THERMAL DATA**

Symbol	Parameter	TO-220	TO-220FP	D <sup>2</sup> PAK	DPAK	Unit
$R_{thj-case}$	Thermal Resistance Junction-case	3	5	3	8	°C/W
$R_{thj-amb}$	Thermal Resistance Junction-ambient	50	60	62.5	100	°C/W

**CONNECTION DIAGRAM (top view)**

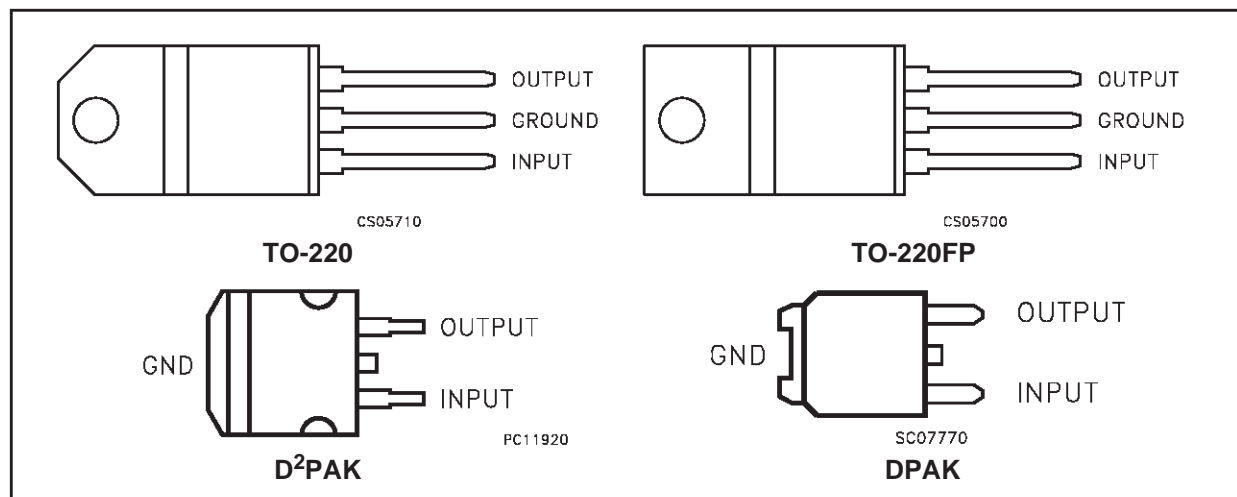

**ORDERING CODES**

ORDERING CODE	PACKAGE
L4941BV	TO-220
L4941BP	TO-220FP
L4941BD2T	D <sup>2</sup> PAK
L4941BDT (*)	DPAK

(\*) Available in Tape & Reel with the suffix "-TR".

## TEST CIRCUITS

Figure 1 : DC Parameter

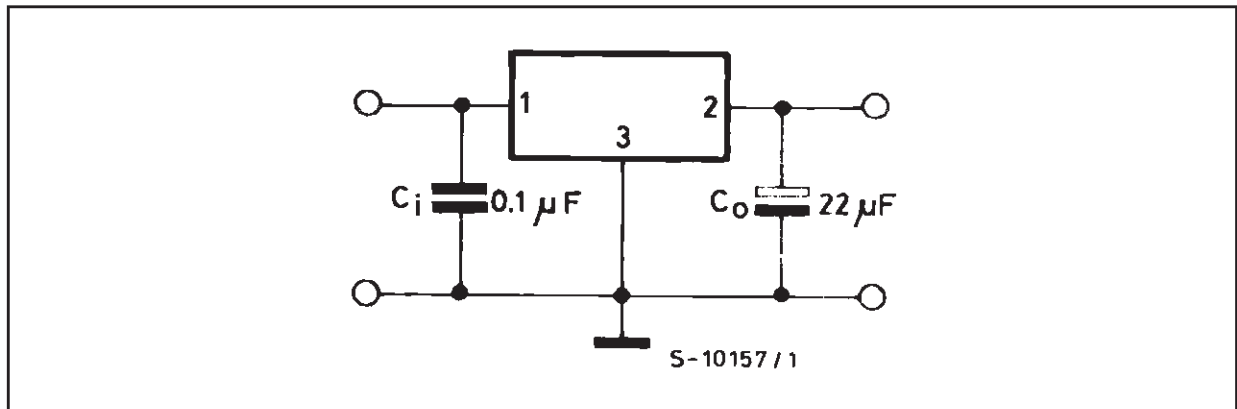

Figure 2 : Load Rejection

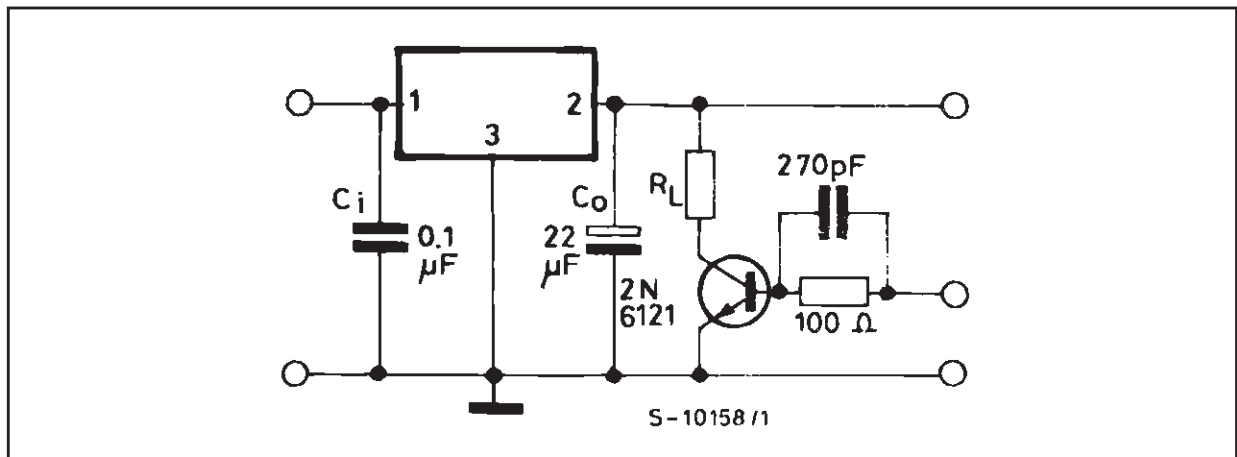
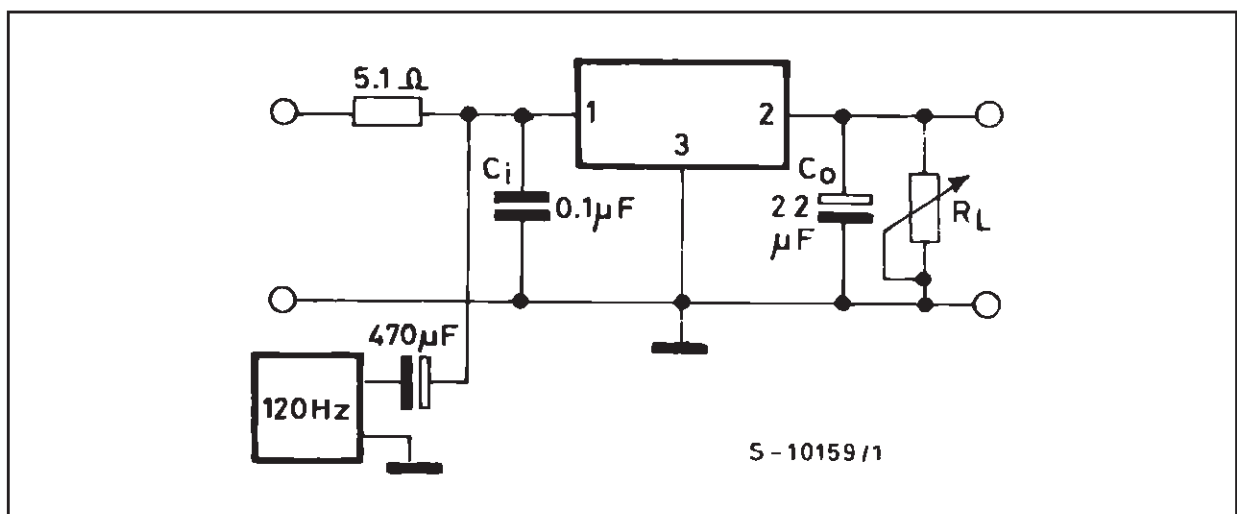

Figure 3 : Ripple Rejection



**ELECTRICAL CHARACTERISTICS** (Refer to test circuit,  $V_I=7V$ ,  $C_1 = 0.1\mu F$ ,  $C_O = 22\mu F$ ,  $T_J = 25^\circ C$ , unless otherwise specified.)

Symbol	Parameter	Test Conditions	Min.	Typ.	Max.	Unit
$V_O$	Output Voltage	$I_O = 5mA$ to 1A $V_I = 6$ to 14V	4.8	5	5.2	V
$V_I$	Input Voltage	$I_O = 5$ mA			16	V
$\Delta V_O$	Line Regulation	$V_I = 6$ to 16V $I_O = 5$ mA		5	20	mV
$\Delta V_O$	Load Regulation	$I_O = 5mA$ to 1A		8	20	mV
		$I_O = 0.5A$ to 1A		5	15	mV
$I_q$	Quiescent Current	$I_O = 5$ mA $V_I = 6V$		4	8	mA
		$I_O = 1A$ $V_I = 6V$		20	40	mA
$\Delta I_q$	Quiescent Current Change	$I_O = 5$ mA $V_I = 6$ to 14V			3	mA
		$I_O = 1A$ $V_I = 6$ to 14V			-10	mA
$V_d$	Dropout Voltage	$I_O = 0.5A$		250	450	mV
		$I_O = 1A$		450	700	mV
$\Delta V_O/\Delta T$	Output Voltage Drift			0.6		mv/°C
SVR	Supply Voltage Rejection	$f = 120Hz$ $I_O = 1A$	58	68		dB
$I_{sc}$	Short Circuit Current	$V_I = 14V$		1.6	2.0	A
		$V_I = 6V$		1.8	2.2	A
$Z_O$	Output Impedance	$f = 1KHz$ $I_O = 0.5A$		30		mΩ
$e_N$	Output Noise Voltage	$B = 100Hz$ to 100KHz		30		$\mu V/V_O$

**TYPICAL CHARACTERISTICS**

**Figure 4 :** Dropout Voltage vs Output Current

**Figure 5 :** Dropout Voltage vs Temperature

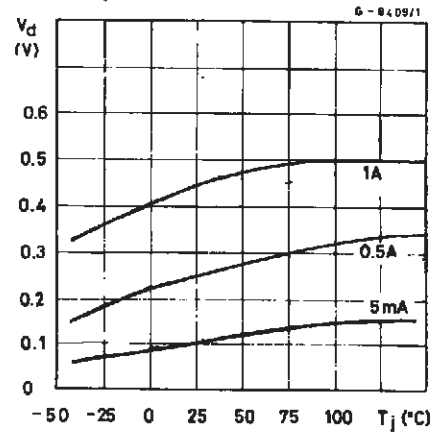
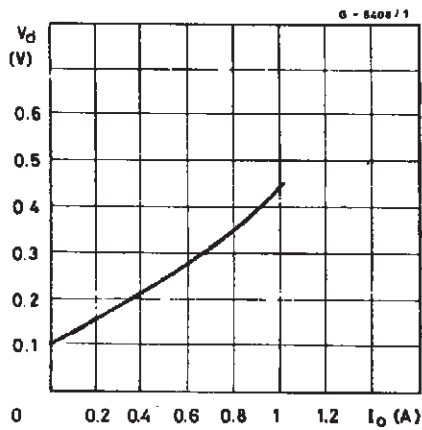

Figure 6 : Output Voltage vs Temperature

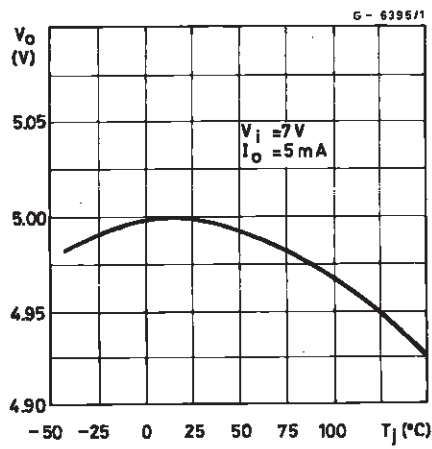

Figure 9 : Quiescent Current vs Output Current

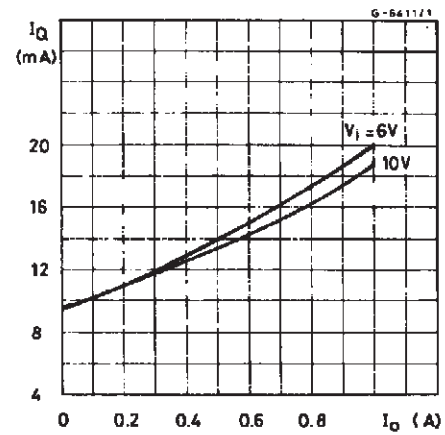

Figure 7 : Quiescent Current vs Temperature

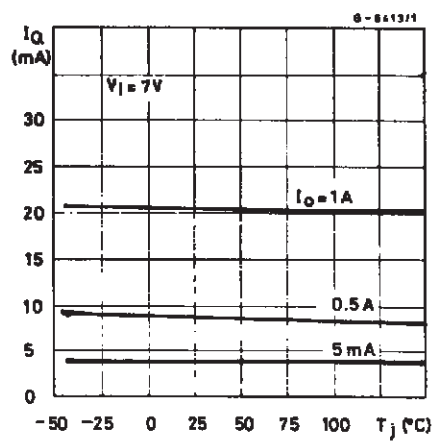

Figure 10 : Short Circuit Current vs Temperature

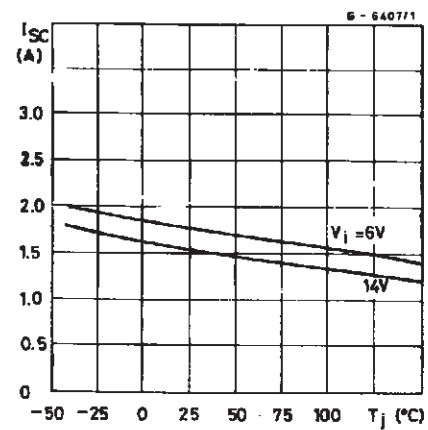

Figure 8 : Quiescent Current vs Input Voltage

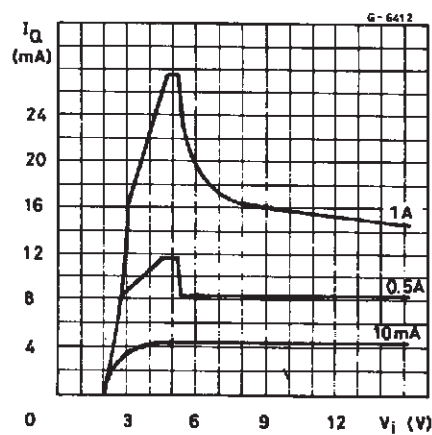

Figure 11 : Peak Output Current vs Input/Output Differential Voltage

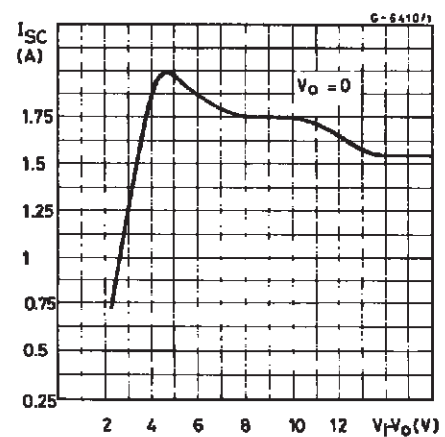

Figure 12 : Low Voltage Behavior

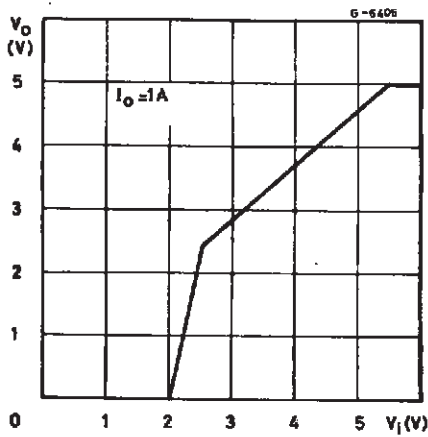

Figure 15 : Load Dump Characteristics

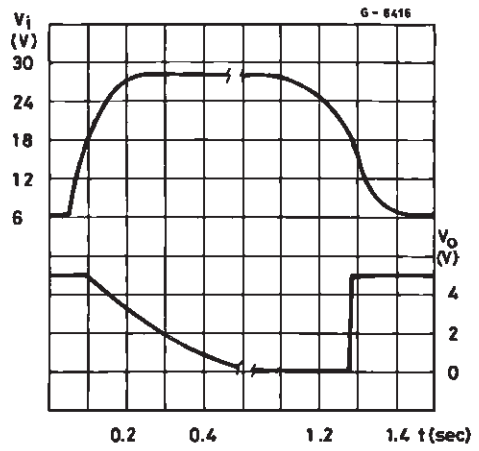

Figure 13 : Supply Voltage Rejection vs Frequency

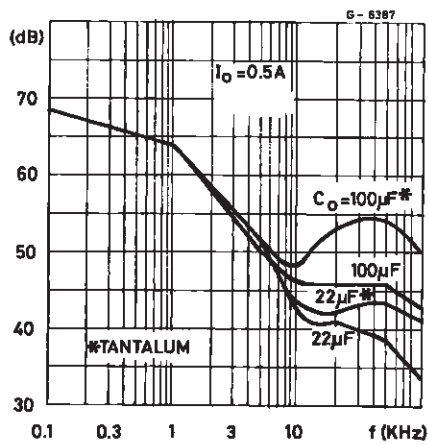

Figure 16 : Line Transient Response

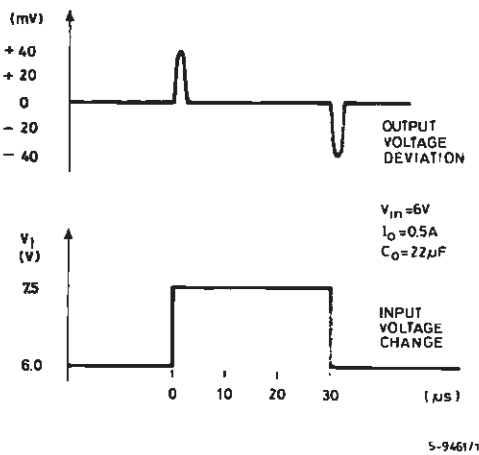

Figure 14 : Supply Voltage Rejection vs Output Current

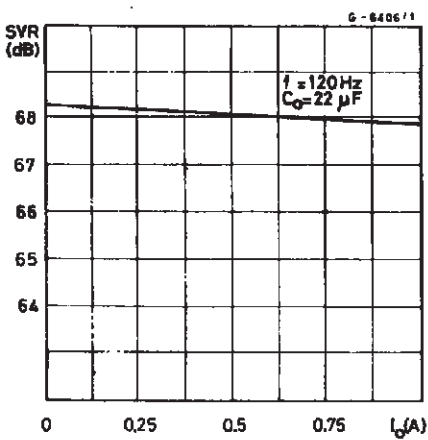

Figure 17 : Total Power Dissipation

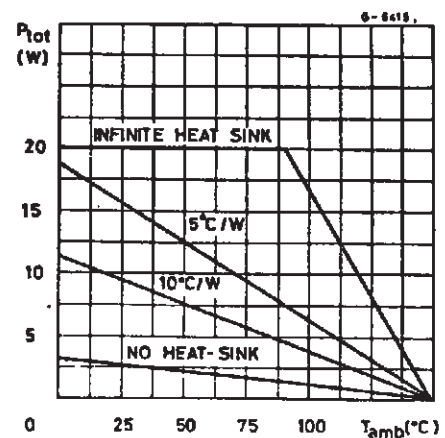

Figure 18 : Load transient Response

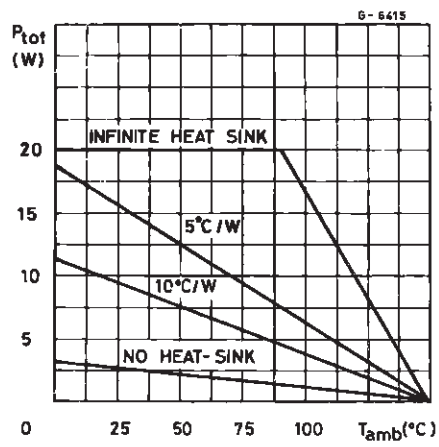

Figure 19 : Distributed Supply with On-card L4940 and L4941 low drop regulator

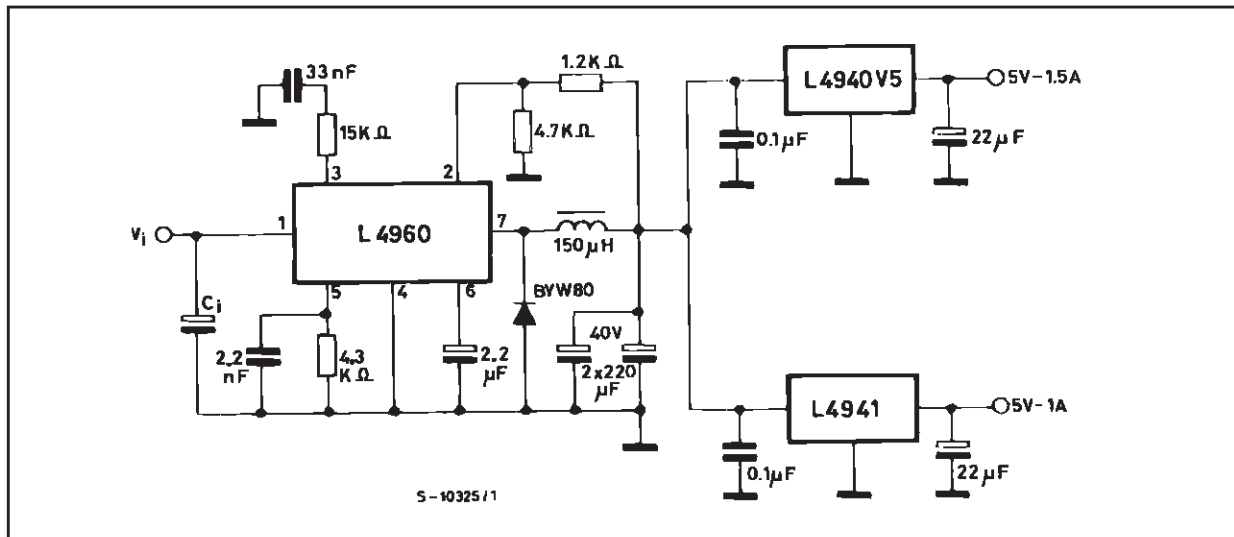
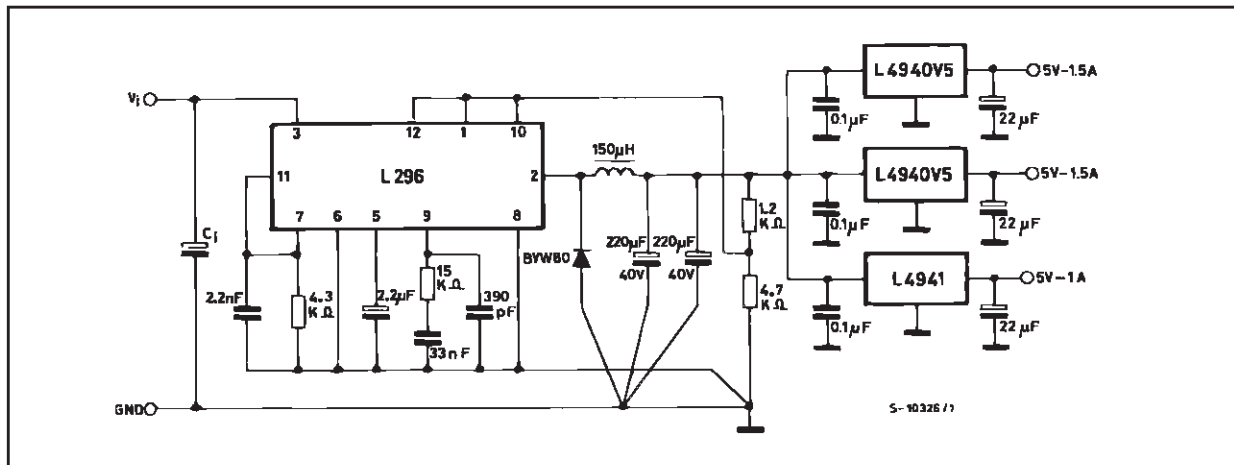

Figure 20 : Distributed Supply with On-card L4940 and L4941 low drop regulator



ADVANTAGES OF THESE APPLICATIONS ARE:

On card regulation with short-circuit and thermal protection on each output.

Very high total system efficiency due to the switching preregulation and very low-drop postregulation



## TO-220 MECHANICAL DATA

DIM.	mm.			inch		
	MIN.	TYP.	MAX.	MIN.	TYP.	MAX.
A	4.40		4.60	0.173		0.181
C	1.23		1.32	0.048		0.051
D	2.40		2.72	0.094		0.107
D1		1.27			0.050	
E	0.49		0.70	0.019		0.027
F	0.61		0.88	0.024		0.034
F1	1.14		1.70	0.044		0.067
F2	1.14		1.70	0.044		0.067
G	4.95		5.15	0.194		0.203
G1	2.4		2.7	0.094		0.106
H2	10.0		10.40	0.393		0.409
L2		16.4			0.645	
L4	13.0		14.0	0.511		0.551
L5	2.65		2.95	0.104		0.116
L6	15.25		15.75	0.600		0.620
L7	6.2		6.6	0.244		0.260
L9	3.5		3.93	0.137		0.154
DIA.	3.75		3.85	0.147		0.151

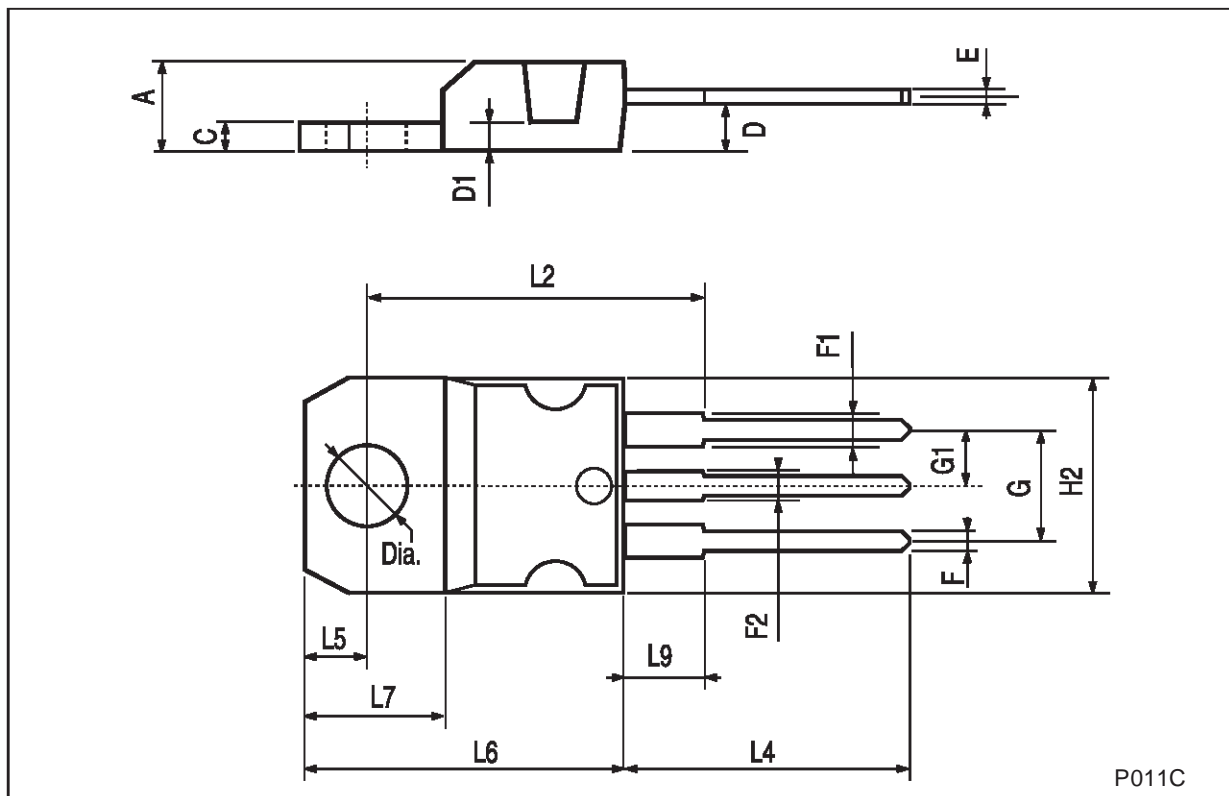

## TO-220FP MECHANICAL DATA

DIM.	mm.			inch		
	MIN.	TYP.	MAX.	MIN.	TYP.	MAX.
A	4.40		4.60	0.173		0.181
B	2.5		2.7	0.098		0.106
D	2.5		2.75	0.098		0.108
E	0.45		0.70	0.017		0.027
F	0.75		1	0.030		0.039
F1	1.15		1.70	0.045		0.067
F2	1.15		1.70	0.045		0.067
G	4.95		5.2	0.194		0.204
G1	2.4		2.7	0.094		0.106
H	10.0		10.40	0.393		0.409
L2		16			0.630	
L3	28.6		30.6	1.126		1.204
L4	9.8		10.6	0.385		0.417
L6	15.9		16.4	0.626		0.645
L7	9		9.3	0.354		0.366
DIA.	3		3.2	0.118		0.126

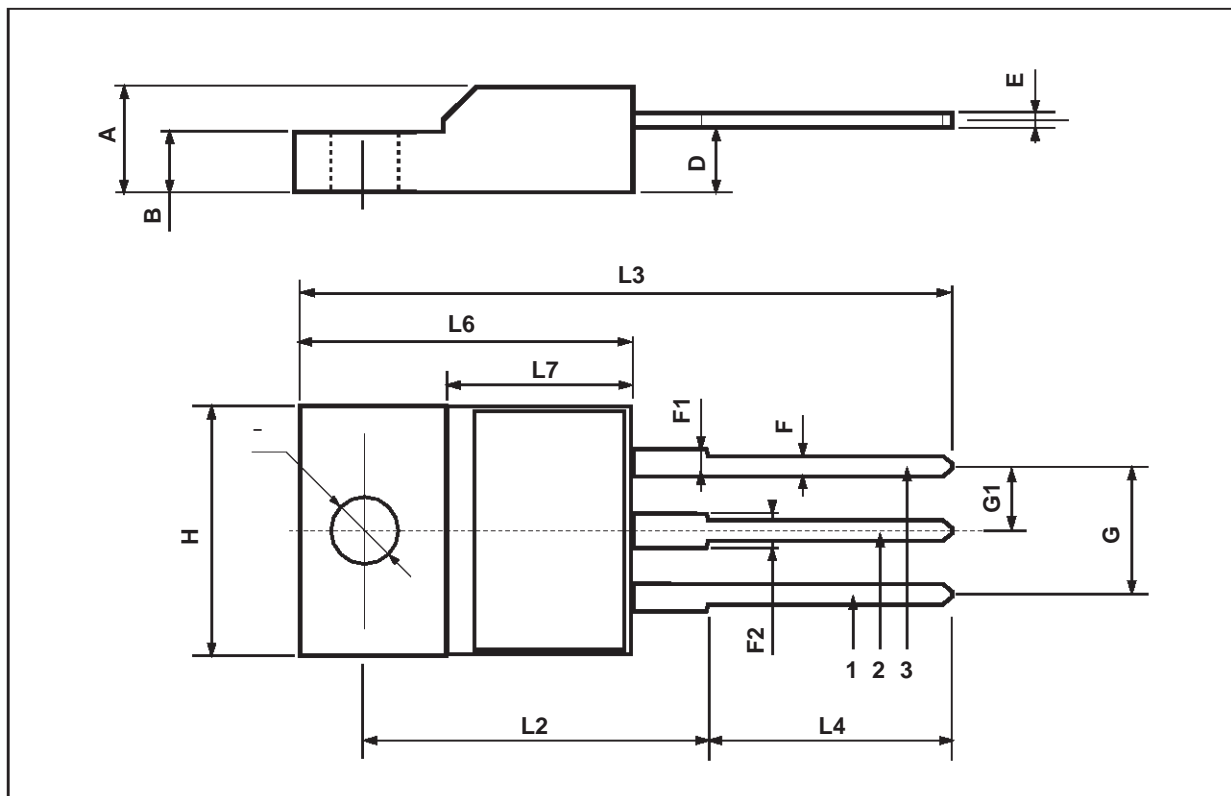

## D<sup>2</sup>PAK MECHANICAL DATA

DIM.	mm.			inch		
	MIN.	TYP	MAX.	MIN.	TYP.	MAX.
A	4.4		4.6	0.173		0.181
A1	2.49		2.69	0.098		0.106
A2	0.03		0.23	0.001		0.009
B	0.7		0.93	0.027		0.036
B2	1.14		1.7	0.044		0.067
C	0.45		0.6	0.017		0.023
C2	1.23		1.36	0.048		0.053
D	8.95		9.35	0.352		0.368
D1		8			0.315	
E	10		10.4	0.393		0.409
E1		8.5			0.335	
G	4.88		5.28	0.192		0.208
L	15		15.85	0.590		0.624
L2	1.27		1.4	0.050		0.055
L3	1.4		1.75	0.055		0.068
M	2.4		3.2	0.094		0.126
R		0.4			0.016	
V2	0°		8°	0°		8°

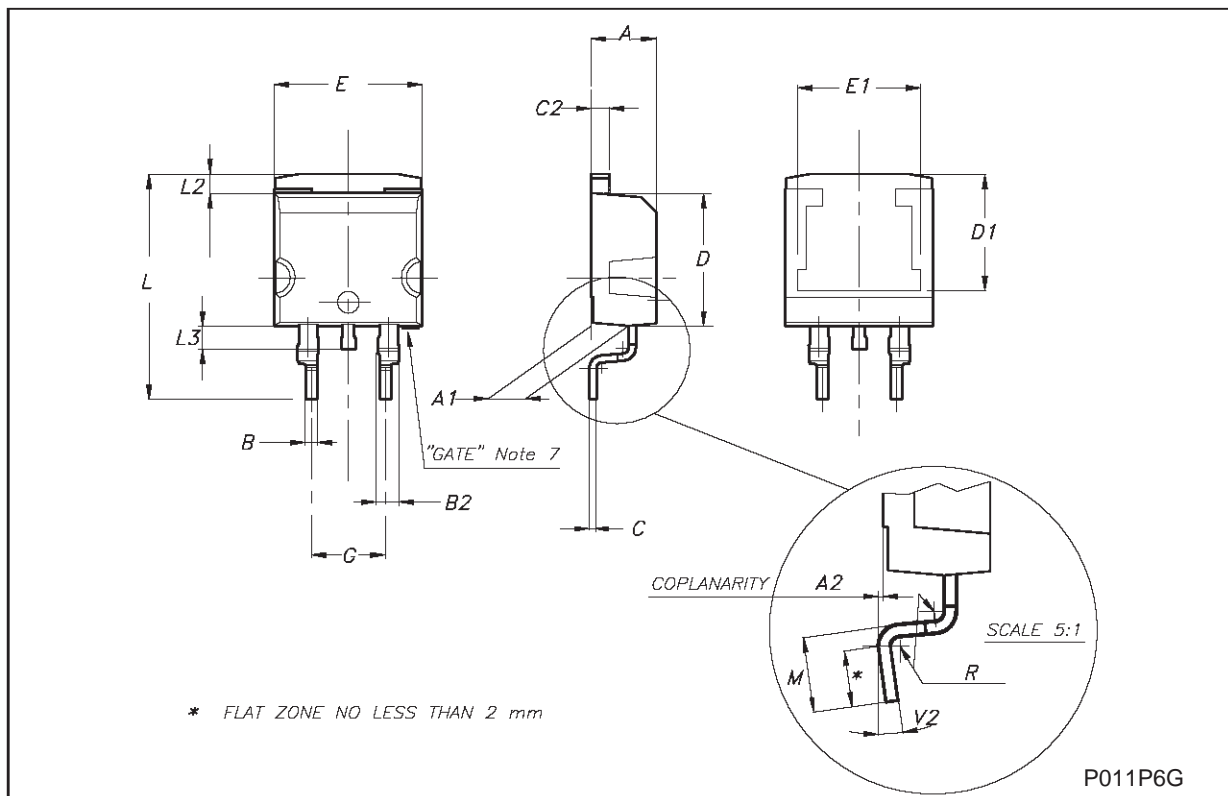

**DPAK MECHANICAL DATA**

DIM.	mm.			inch		
	MIN.	TYP	MAX.	MIN.	TYP.	MAX.
A	2.2		2.4	0.086		0.094
A1	0.9		1.1	0.035		0.043
A2	0.03		0.23	0.001		0.009
B	0.64		0.9	0.025		0.035
B2	5.2		5.4	0.204		0.212
C	0.45		0.6	0.017		0.023
C2	0.48		0.6	0.019		0.023
D	6		6.2	0.236		0.244
E	6.4		6.6	0.252		0.260
G	4.4		4.6	0.173		0.181
H	9.35		10.1	0.368		0.397
L2		0.8			0.031	
L4	0.6		1	0.023		0.039

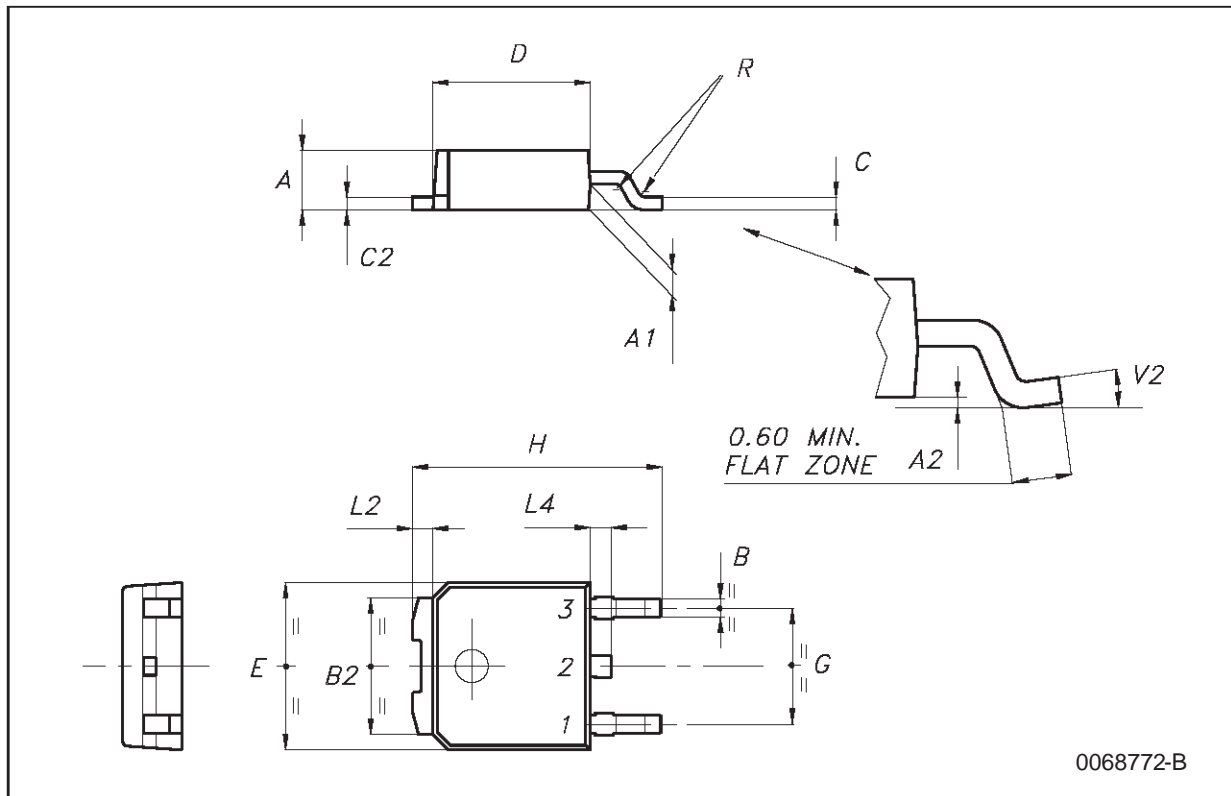

0068772-B

Information furnished is believed to be accurate and reliable. However, STMicroelectronics assumes no responsibility for the consequences of use of such information nor for any infringement of patents or other rights of third parties which may result from its use. No license is granted by implication or otherwise under any patent or patent rights of STMicroelectronics. Specifications mentioned in this publication are subject to change without notice. This publication supersedes and replaces all information previously supplied. STMicroelectronics products are not authorized for use as critical components in life support devices or systems without express written approval of STMicroelectronics.

© The ST logo is a registered trademark of STMicroelectronics

© 2001 STMicroelectronics - Printed in Italy - All Rights Reserved  
STMicroelectronics GROUP OF COMPANIES

Australia - Brazil - Canada - China - Finland - France - Germany - Hong Kong - India - Israel - Italy - Japan - Malaysia - Malta - Morocco  
Singapore - Spain - Sweden - Switzerland - United Kingdom - United States.

© <http://www.st.com>



This datasheet has been download from:

[www.datasheetcatalog.com](http://www.datasheetcatalog.com)

Datasheets for electronics components.