

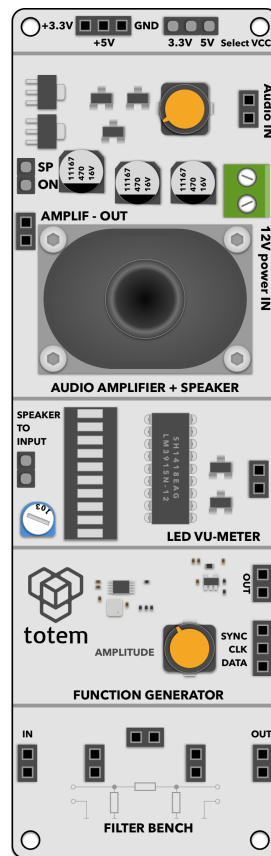

totem

MiniLab

Side panel 3



Totem by UAB Aldrea

ver 1.1

Overview

This is a getting started guide for the third expansion board for the Totem MiniLab system. This board focuses attention to the analog audio side of electronics, and contains an enclosed, fully self-sufficient audio generation, visualisation and output loop.

In this document we'll go over all of the available modules in the board, together with explanations on their interface with the MiniLab as well as usage examples.

Side panels are meant to bring easy access to commonly used components that are difficult to wire on breadboards due to their dimensions, or require additional equipment to operate them. Side panels give a plug and play interface that lets users to concentrate on experiments or learning, rather than spending time solving issues on how to interface with the part.

This document is divided into sections where each separate module is described. In the side panel 3 these modules are available for use:

- **Audio amplifier with speaker** — AB class discrete audio amplifier with integrated loudspeaker. Can route amplified audio signal either to the speaker or to external sink via breadboard pins. Capable of outputting up to 1 W of RMS power. Works with 12 V voltage source.
- **LED VU-meter** — Audio signal volume unit (VU) with 10 bar LED display. Works in approximately 3dB/step, 30 dB range. Has an integrated sensitivity adjustment potentiometer
- **Function generator** — sine, square and triangle wave generator capable of outputting up to 12.5 MHz signals. Output amplitude can be adjusted with integrated potentiometer, and generator can be controlled through digital interface.
- **Filter bench** — simple pi-filter prototyping module, where you can quickly prototype and experiment with different filters. It's designed to take in regular THT components, such as resistors, capacitors and inductors in the three available spaces. The effect on signals can be immediately observed with neighbouring audio amplifier.

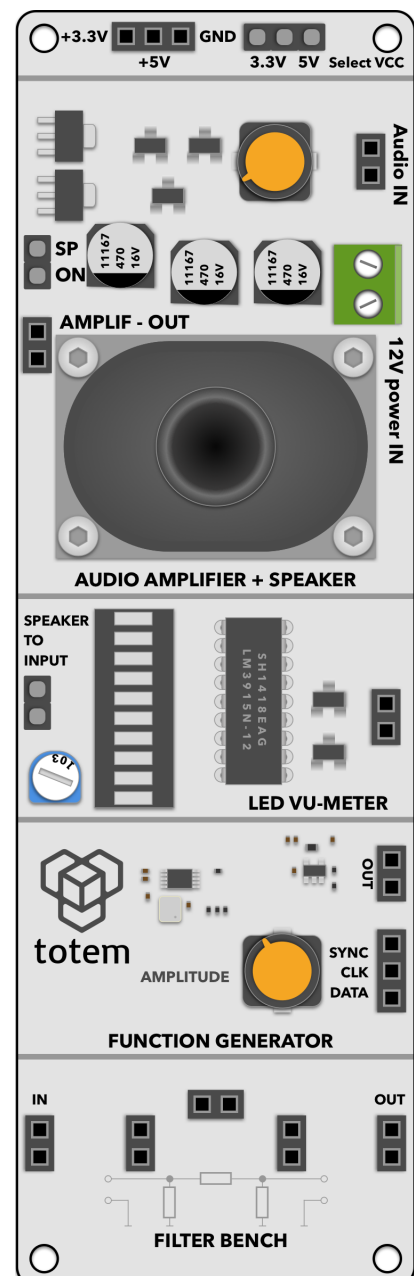

Modules

In the board only the supply power is shared between modules. Otherwise they're fully isolated from one another, and can be used independently. Logic level for digital signals have a jumper which selects the boards to work either at 3.3 or 5 V logic level. It's important for the side panel to have the same logic level as the controller board (e.g., TotemDuino), for best results.

Audio amplifier with speaker

This is an AB class discrete audio amplifier module, capable of up to 1 W output RMS power. Module is designed to work from externally applied 12 V line with connector J1 or contact terminal H6. Input volume is adjusted with potentiometer P1.

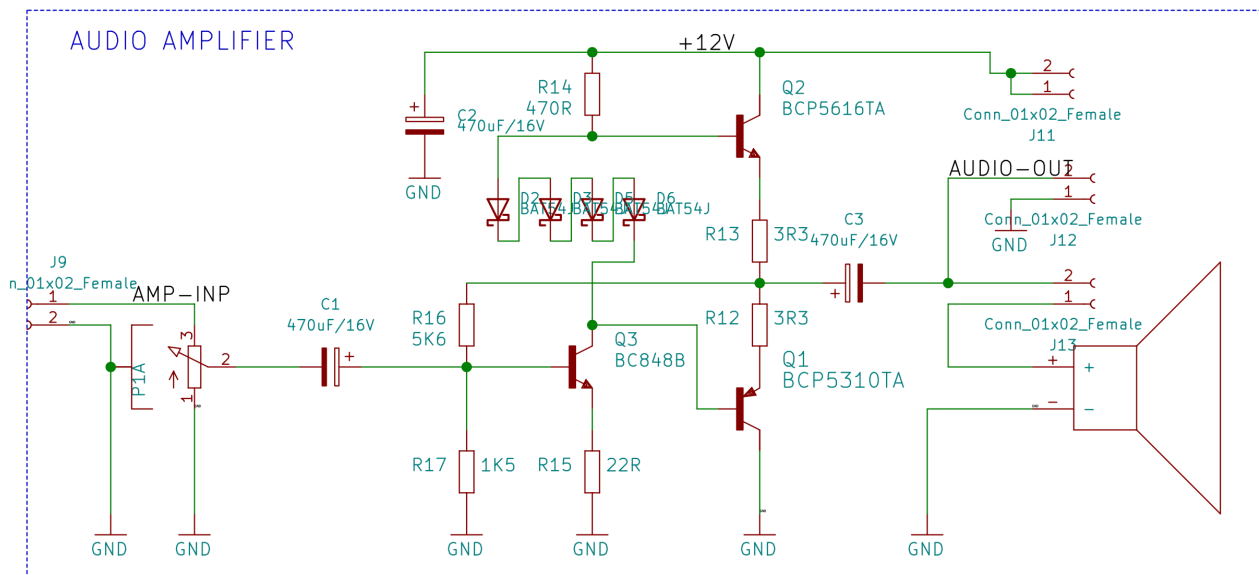

Fig. 1 Audio amplifier schematic.

Inbuilt speaker is enabled by connecting a jumper to JP2 connector, amplified signal output can be connected with a H4 female connector.

You can use the function generator as a signal source (described below) by just connecting a jumper cable between amplifier input and generator output. Another possible input source is using Totem side panel 1 microphone module.

While the amplifier will work in a wide input voltage range, the upper voltage limit is 12 V. You can use the same 12 V used to power miniLab by connecting into VIN line on the miniLab board.

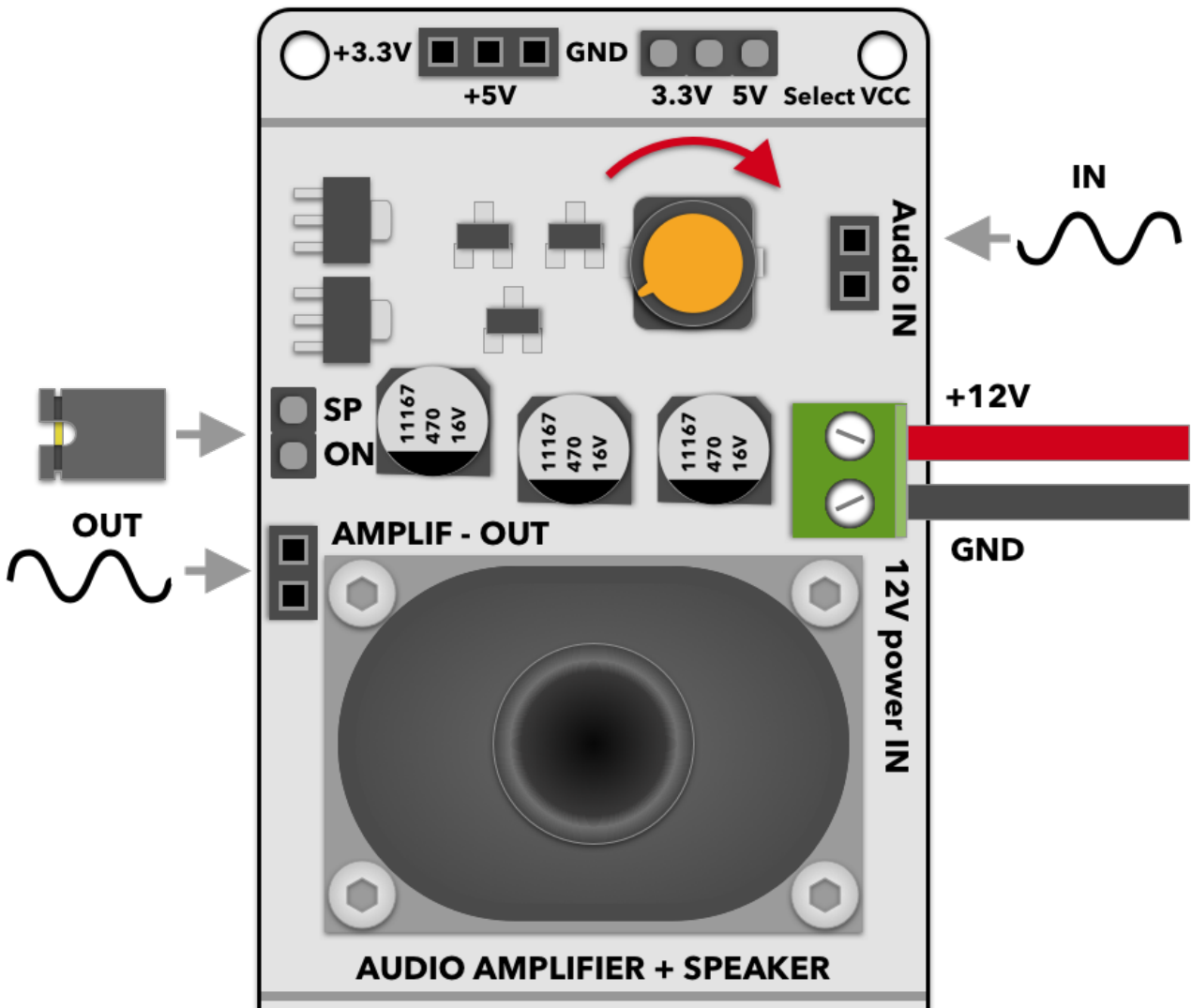

Fig. 2 Using amplifier module.

VU Meter

An Audio Volumetric Unit (VU) meter module is relying on a 10-bar LED display as an output. Each bar represents a 3dB change in the input signal level. The module shares the same 12 V voltage supply line as the audio amplifier module described above.

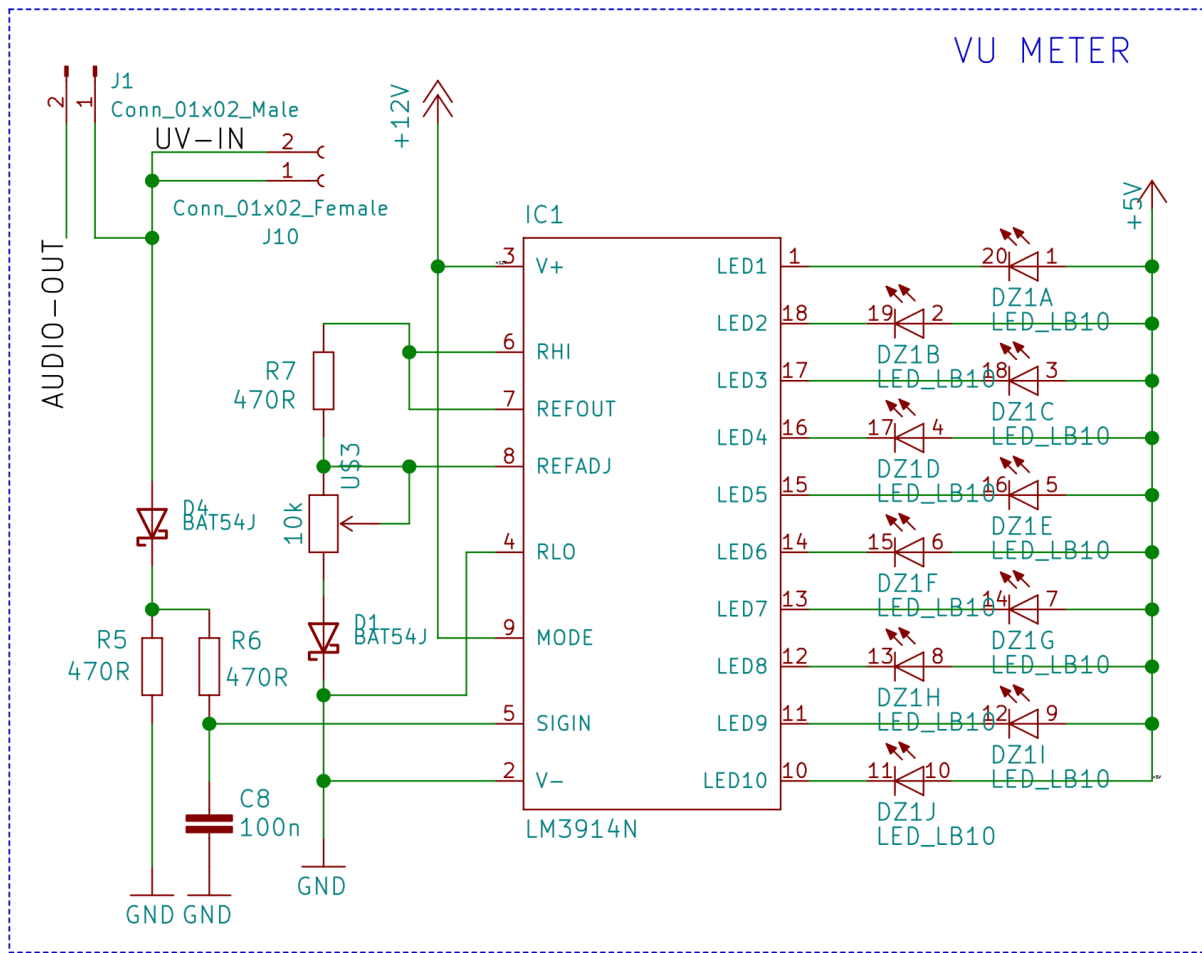

Fig. 3 VU meter schematic.

Input signal level sensitivity can be adjusted by potentiometer U\$3. We suggest that before using the module a calibration sequence be performed – apply the maximum allowed input signal to the module, and turn the potentiometer until all LED are lit, except top 3 which are red. During use lit red LEDs will then indicate overload of the input level.

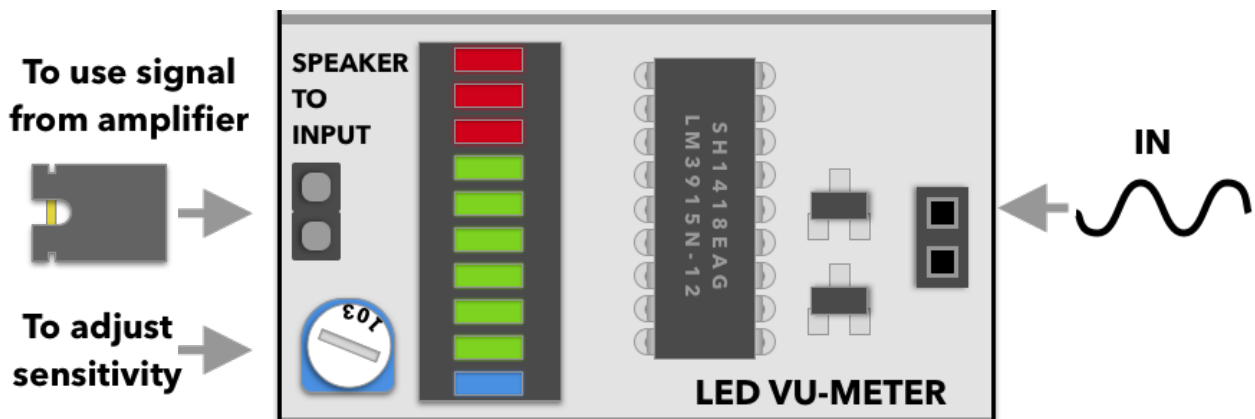

Fig. 4 Using VU meter.

Function generator

This module consists of a digitally controlled function generator AD9833 chip. It is capable to generate sine, triangle and square wave output signal in up to 12.5 MHz frequency. Generated signal is buffered with an operation amplifier, giving user the ability to control output signal amplitude.

We suggest to use and supply sample library to communicate with generator chip from TotemDuino microcontroller board. For the latest version of it please check out our gitlab page at <https://github.com/totemaker>.

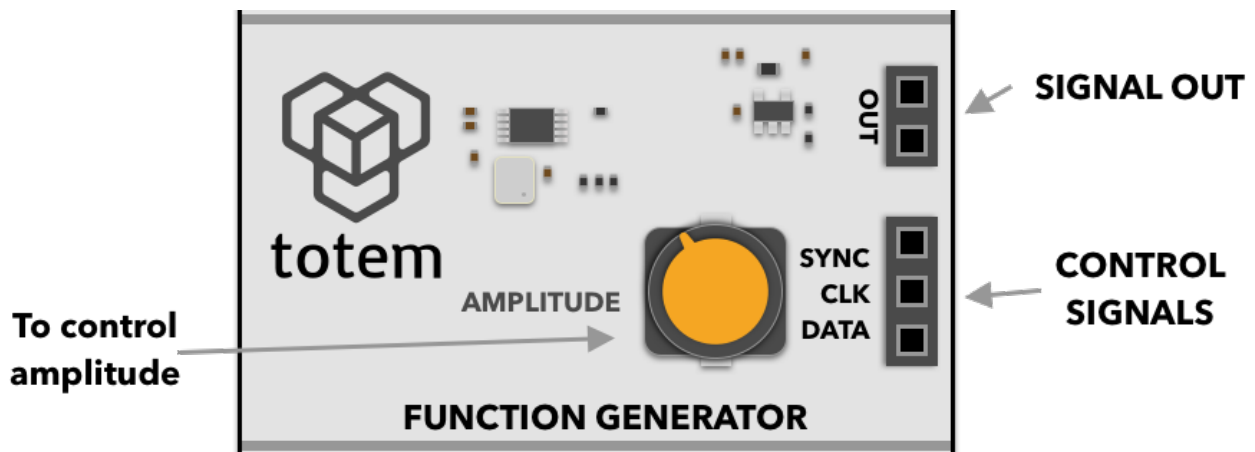

Fig. 6 Using function generator.

Output of the function generator can be wired to the input of audio amplifier, allowing you to hear the output of it with no extra parts. Additionally, filter bench module can be placed between those modules to also experiment with pi-filters, and its effect to the signal.

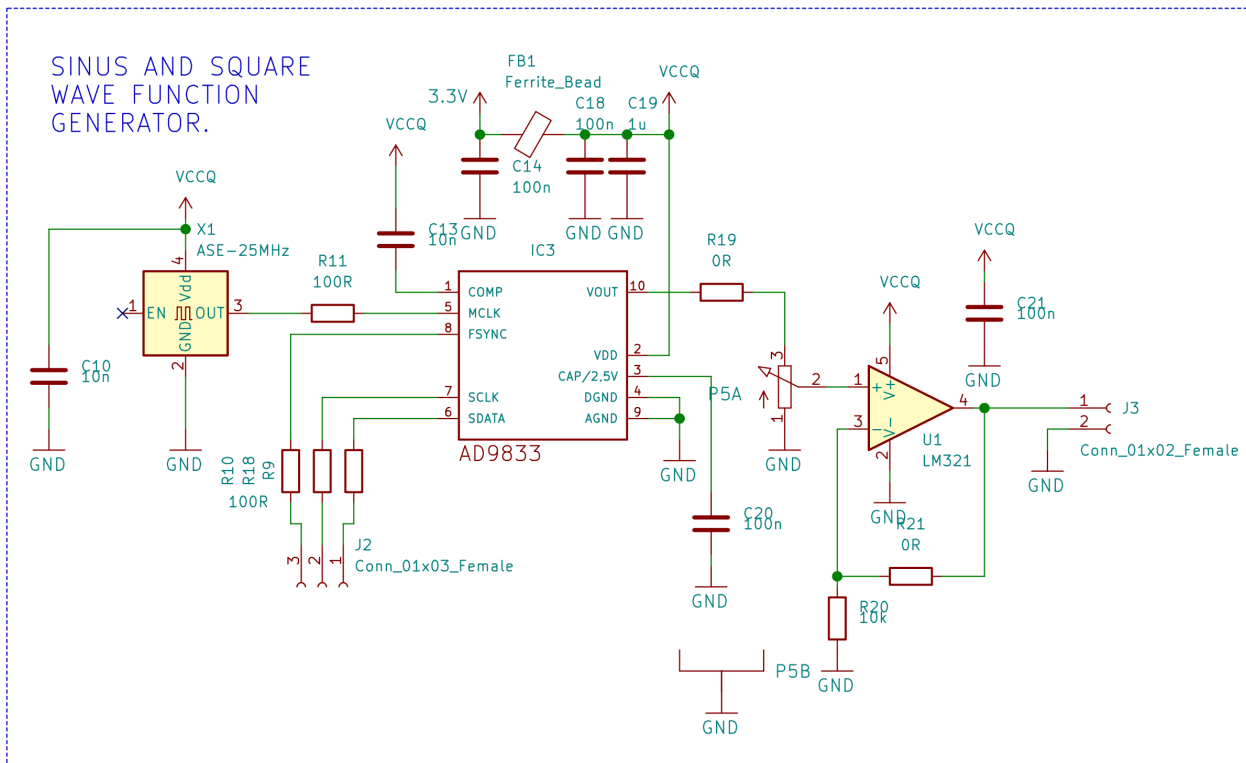

Fig. 5 Function generator schematic.

Filter Bench

This is a simple framework for experimenting with pi-type filters. It allows you to easily connect different THT components, such as resistors, capacitors and inductors. Filter bench module is meant to be used as middle module between signal generator and audio amplifier modules, allowing user to quickly experience the effect that various components has on the signal.

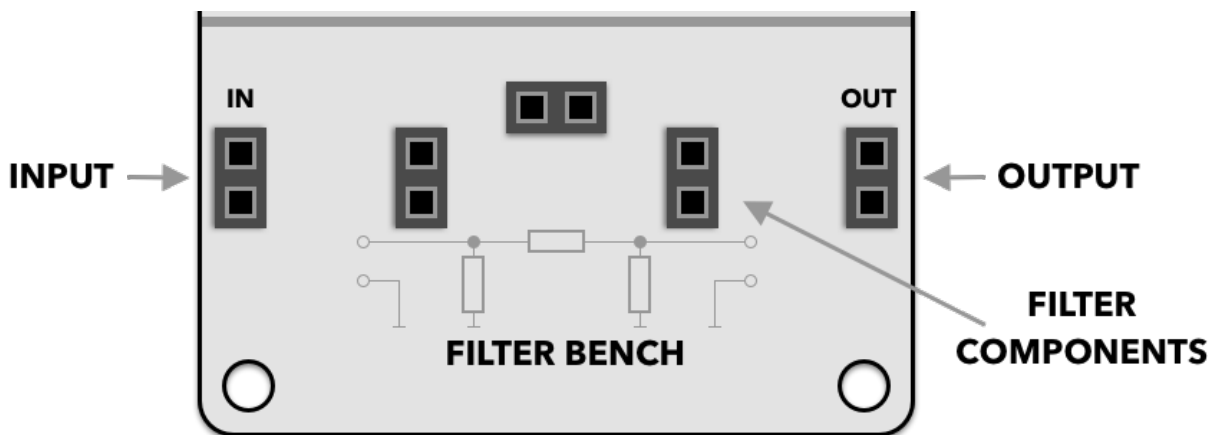

Fig. 7 Using filter bench.

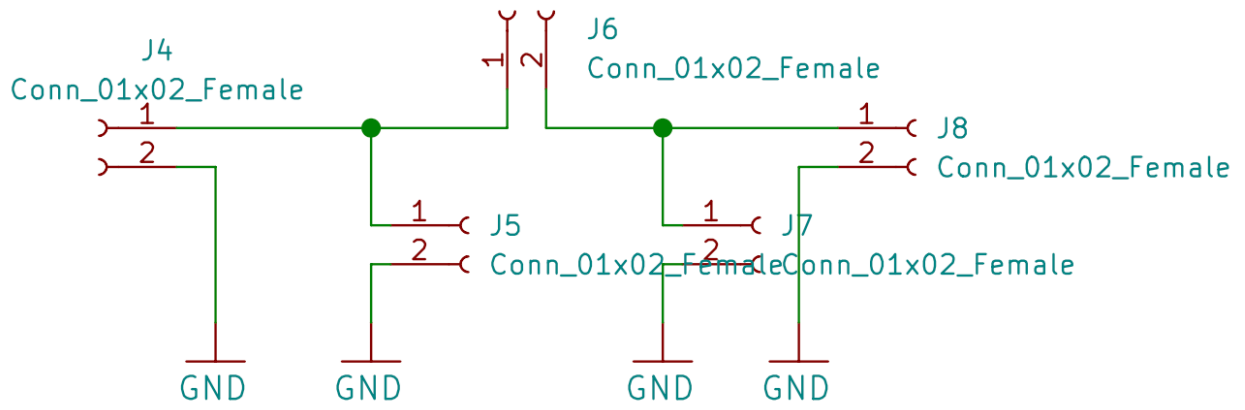

Fig. 7 Filter bench schematic

Mounting

We suggest using the following guide for side panel mounting to the MiniLab workbench:

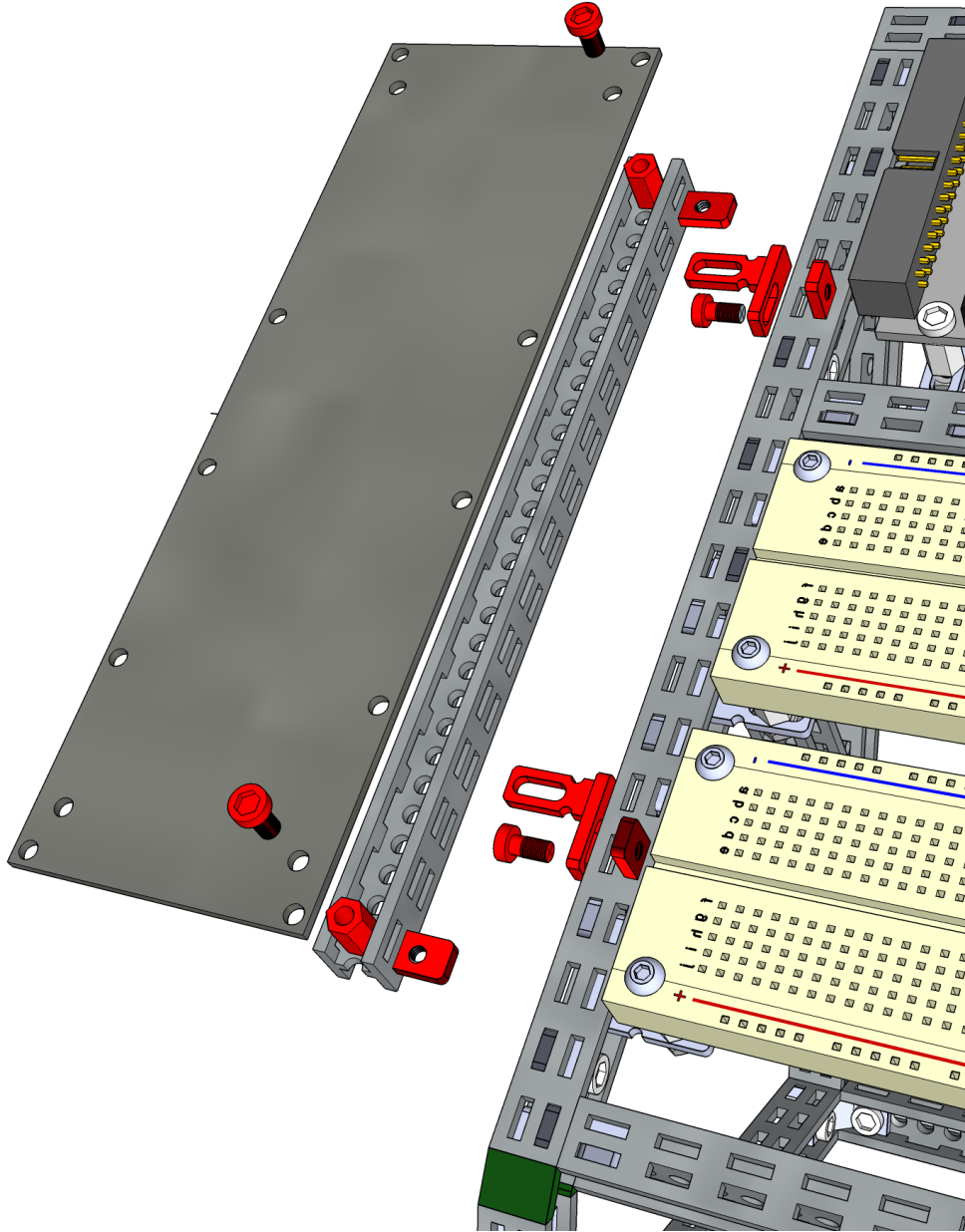

Fig. 8 Side panel mounting to the MiniLab

In this case, the sub-assembly can be easily taken off by sliding the pins from the sockets. If a more permanent assembly is needed, nuts and screws can be used to fix the sidepanel in place.

