

# TF02 Single-point Ranging LiDAR Product Specification



Benewake (Beijing) Co. Ltd.



## Preface

Dear users,

We would like to express our gratitude to you for choosing our products.

This specification is aimed at helping you use our product in a proper manner. Before you install and use the product, please make sure you have carefully read the documents attached, which will contribute to your better using of our product. If you have read this specification, please keep it properly for future reference.

If you have any questions or problems about our product, please feel free to contact our technical support or aftersales customer service. We will try our best to solve any problem related to the product. If you have any advice or suggestion for us, please go to our official website ([www.benewake.com](http://www.benewake.com)) and give us feedback in the community module. We listen to every customer wholeheartedly.

Benewake aims to make the best “Robotic Eyes” worldwide. We always adhere to the “customer experience centered” principle.

## Table of Contents

1. Product Overview .....	4
2. Optical Principle .....	4
3. Electrical Properties.....	4
4. Product Properties.....	4
5. Protection .....	5
5.1 Protection Grade .....	5
5.2 Anti-pesticide corrosion.....	6
6. Detection Angle .....	7
7. Dimension and Product Specification .....	7
8. Noise Model .....	9
9. Data Format .....	9
9.1 Communication Protocols.....	9
9.2 Standard Data Format of Serial Ports.....	9
9.3 Data Format of Serial Port Pix.....	10
9.4 CAN Standard Data Format .....	10
10. Interface Description of Serial Port Upper Computer .....	11



### 1. Product Overview

The product is based upon ToF (Time of Flight), supplemented by particular optics, electricity, and design, so as to measure distance with stability, precision, high sensitivity, and high speed.

Key Features:

- High sensitivity, and able to measure as far as 22 meters
- High speed measurement with a maximum sampling frequency of 100Hz
- Excellent anti-ambient light usability (operable under 100kLux ambient light)
- Protection grade: IP65
- Anti-corrosive against pesticide
- Small in size and light

Major Applications:

- Drone altitude holding and terrain following
- Machine control and safety sensors
- Range measuring instrument

### 2. Optical Principle

TOF is short for Time of Flight. It refers to that a sensor emits modulated near infrared light, which reflects when objects are in the way. TOF then converts the distance away from the filmed scenery by calculating the time difference or phase difference between emission and reflection, thereby generating in-depth information.

### 3. Electrical Properties

Item	Symbol	Minimum Value	Typical Value	Maximum Value	Unit
Power Supply Voltage	DC	4.5	5 (≥1A)	6	V
Average Power	P		1		W
Peak Current	I <sub>p</sub>		1		A
Serial Port TTL Electrical Level	LVTTTL		0~3.3		V

### 4. Product Properties

Item	Symbol	Condition or Description	Typical Value	Unit
Operating Range	L	Indoor	0.4 - 10 (reflectivity 10%) 0.4 - 22 (reflectivity 90%)	m
		Outdoor illumination intensity of 100Klux	0.4 - 10 (reflectivity 30%)	
Emission Semi-angle of Signal Light	α	Divergence angle of light spot	2	Degree



Signal Acceptance Semi-angle	$\beta$	Semi-angle of LiDAR's effective detection	1.5	Degree
Range Resolution	Re	Sensitivity to range change	1	cm
Range Repeatability	$\sigma$	1 $\sigma$ standard deviation of indoor repetitive ranging	<1 (within 10m) <2 (10m-22m)	cm
Range Accuracy	$\Delta$	Deviation between measuring range and actual distance	<6 (within 5m) $\varnothing$ <2% (5m-22m)	cm
Light Source	$\lambda$	Central wave length	850	nm
Operating Temperature	T		-10~60	° C
Protection Grade	IP		IP65	
Eye Safety	S	Compliance with EN62471	NA	
Weight	W	Connection line included	52	g
Size	LWH	Length*Width*Height	69*46*26	mm

$\varnothing$ The reflectivity of black standard board is 10%. And the reflectivity of white standard board is 90%.

$\varnothing$ The testing environment is indoor white standard board.

## 5. Protection

### 5.1 Protection Grade

INGRESS PROTECTION (IP) Protection Grade System is drafted by INTERNATIONAL ELECTROTECHNICAL COMMISSION (IEC) to classify electrical appliances according to their dust and moisture resistance characteristics. IP protection grade is composed of two figures, the first representing the grade of electrical appliance dust proof and preventing the intrusion of foreign objects, and the second representing degree of electrical appliance moisture proof and water proof. The greater the number is, the higher the degree of protection is.

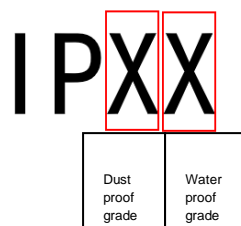

Protection grade of TF02: IP65, IP dust proof: Grade VI, IP water proof: Grade V.

Grade VI of IP dust proof represents the full prevention from intruding by foreign object and dust.



Grade V of IP dust water represents the prevention from damaging the electrical appliance by the intrusion of water from the nozzle at different directions.

TF02 protection grade can ensure its normal operation under light rain, moderate rain, pesticide spraying by drone and polluted optical windows.

If the operating environment is harsh, and you would like to know more about the impact of optical window pollution, please contact us for TF02 Single-point Ranging LiDAR Pollution Test Report.

## 5.2 Anti-pesticide corrosion

With special ratio and test, TF02 shell material is different from the traditional plastic material, and more resistant to pesticide corrosion, so it can work normally in the harsh outdoor environment. Especially in the field of plant protection drone, anti-pesticide corrosion can greatly improve the product's reliability and life.

TF02 shell consists of two materials, as shown in the figure below. Material A and material B, respectively, constitute its shell and optical window. The two materials will go through the following pesticide corrosion test: the two materials were respectively and completely submerged in nine pesticides diluted 100 times for at least 48 hours.

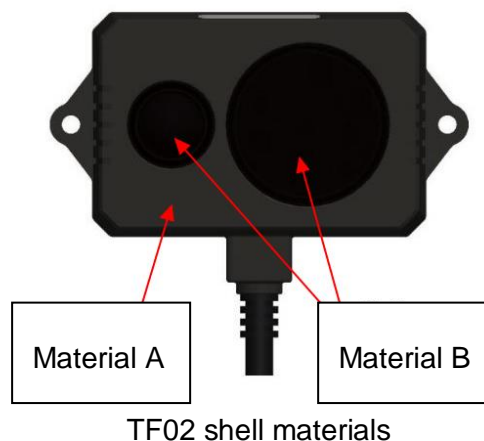

TF02 shell material corrosion test results are shown in the following table, where material A (shell) is completely free from pesticide corrosion and material B (optical window) is partially corroded. As the pesticide concentration and contact area of test materials with pesticide under our test conditions are higher or greater than those in normal environment, it has a high anti-pesticide corrosion characteristic.

TF02 shell material pesticide corrosion test table

No.	Tested pesticide type	Material A (Shell)	Phenomenon	Material B (Optical window)	Phenomenon
1	Deltamethrin	√		√	
2	Cypermethrin	√		×	Surface corrosion
3	Copper sulfate basic	√		√	
4	Glyphosate	√		√	
5	Glufosinate	√		√	
6	Azoles	√		√	
7	Hymexazol	√		×	Surface



					corrosion
8	Phenoxy acetic acid	√		×	There is corrosion, and material becomes soft
9	Trifluralin	√		×	There is corrosion, and material becomes soft

Description: in the test, diluted 100 times refers to the ratio of pesticide and water of 1: 100, that is, the proportion of pesticide is 1%. The proportion of pesticides in the test is higher than common pesticide proportion (0.1%-1%). The test product is completely immersed in nine pesticides for at least 48 hours. √ indicates that the material is completely free from corrosion, and × indicates that the material is affected by corrosion.

### 6. Detection Angle

TF02's signal acceptance angle is 3°, so LiDAR's detection angle is 3°. The side lengths of different distance detection ranges (the detection range takes on a square shape) are shown as below in the table.

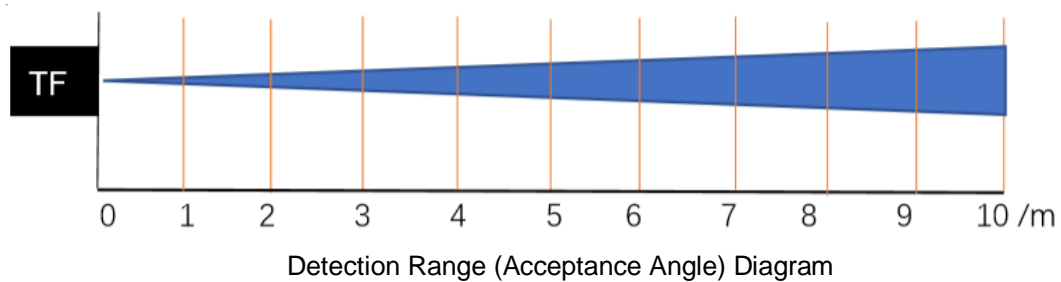

Distance (m)	1	2	3	4	5	6	7	8	9	10	15	20	22
Detection Range Side Length (cm)	5	10	16	21	26	31	37	42	47	52	79	105	115

Note: the distance in the table stands for the vertical distance between LiDAR and the detected object, with meter as unit. The side length unit of detection range is cm. Generally, the side length of detected object should be greater than that of detection range. Only in this way the LiDAR output data can be reliable. When the side length of detected object is less than that of detection range, the LiDAR output data is not stable and the error increases.

Note: the side length of detecting range is not equal to the object resolution at the corresponding distance.

### 7. Dimension and Product Specification

The following module object figures and outline dimensional drawings are all reference designs, and can be customized according to customers' requirements and actual application scenarios.





DELiDAR TF02 Outline Drawing

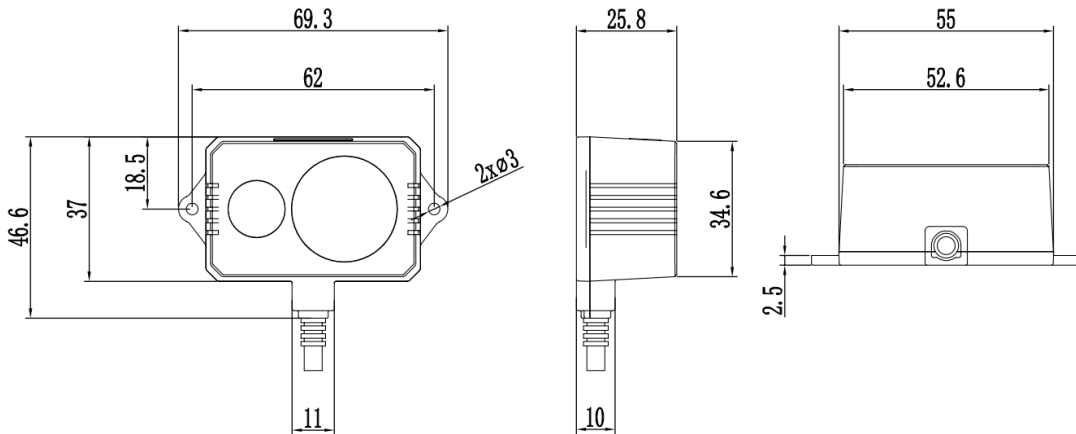

DELiDAR TF02 Outline Dimensional Drawing (unit: mm)

**Installation Requirements:**

- 1、 M2.5 round Philip's head screw is suggested when installing LiDAR and peripheral structures.
- 2、 Optical windows of LiDAR front panel cannot be blocked and shall be kept clean.

**Line Sequence Description:**

	Line Sequence of Serial Ports	Line Sequence of CAN Port
Red Line	+5V	+5V
Black Line	GND	GND
White Line	TTL-RXD	CAN-L
Green	TTL-TXD	CAN-H





Line		
------	--	--

## 8. Noise Model

The repeat accuracy of LiDAR testing distance is relevant to Strength (signal strength). The higher the Strength is, the more stable the dist is, and the less the standard deviation of dist is.

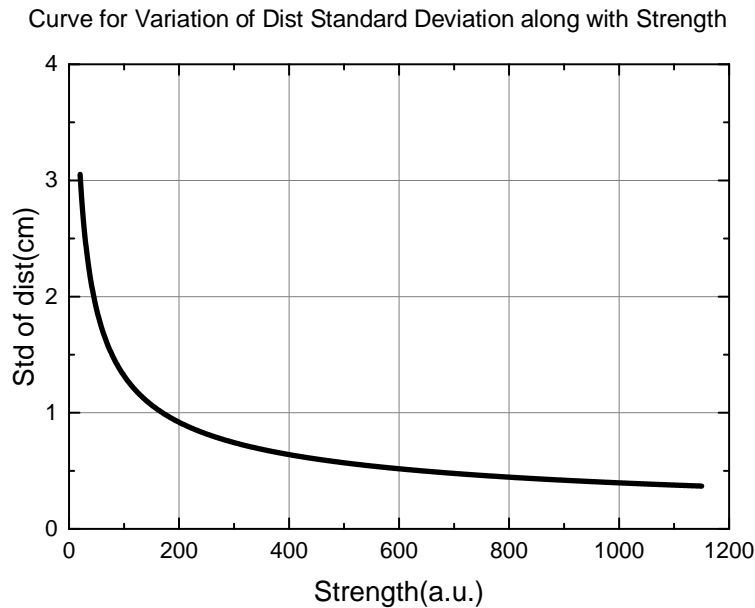

Curve for Variation of Dist Standard Deviation along with Strength

## 9. Data Format

### 9.1 Communication Protocols

The following is an introduction to the method of DE-LiDAR TF02 connecting and communicating with peripheral equipment using serial ports or CAN, including coded format of sent data and communication protocols of modules with peripheral equipment. The serial port output level is LVTTTL (0-3.3V).

Communication	UART	CAN
Baud Rate	115,200	1M
Data Bit	8	--
Stop Bit	1	--
Parity Bit	None	--
None	--	0x00090002
Frame Format	--	Extended Frame

### 9.2 Standard Data Format of Serial Ports

The data output by TF02 is shown as below. All the data are hexadecimal. Each frame of data totals 9 bytes. The data contains distance information, i.e. Dist; signal strength information, i.e. STRENGTH; and reliability information, i.e. SIG. The frame end is data parity bit.



Data Bit	Definition	Description
Byte0	Frame header	0x59
Byte1	Frame header	0x59
Byte2	DIST_L	DIST low 8 Bits
Byte3	DIST_H	DIST High 8 Bits
Byte4	STRENGTH_L	STRENGTH low 8 Bits
Byte5	STRENGTH_H	STRENGTH high 8 Bits
Byte6	SIG	Reliability is divided into 8 levels, respectively indicated by 0x01-0x08. When the reliability level is 7 or 8, it means data is reliable. When the reliability level is another value, the data of this frame is not recommended.
Byte7	TIME	Exposure time is divided into two levels and expressed by 0x03 and 0x06 respectively. The greater the value is, the longer the exposure time is.
Byte8	Check	Low 8 bits of Checksum parity bit, Checksum = Byte0 + Byte2 + ... + Byte7, Checksum are the low 8 bits of the checksum of former 8 bytes

### 9.3 Data Format of Serial Port Pix

It is output in the form of strings with m as its unit. For example, if the measuring distance is 1.21m, then the output string is 1.21. Each distance value ends with line feed.

Note: if the output distance of TF02 is 22 (m), it indicates outrange or insufficient signal intensity and so the distance is not reliable. It is suggested to eliminate this data.

### 9.4 CAN Standard Data Format

The data output by TF02 is shown as below. All the data are hexadecimal. Each frame of data totals 8 bytes. The data contains distance information, i.e. Dist; signal strength information, i.e. STRENGTH; and reliability information, i.e. SIG.

Note: CAN communication protocols can be customized according to customer requirements.

Data Bit	Definition	Description
Byte0	DIST_H	DIST High 8 Bits
Byte1	DIST_L	DIST low 8 Bits
Byte2	STRENGTH_H	STRENGTH high 8 Bits
Byte3	STRENGTH_L	STRENGTH low 8 Bits



<b>Byte4</b>	TIME	Exposure time is divided into two levels and expressed by 0x03 and 0x06 respectively. The greater the value is, the longer the exposure time is
<b>Byte5</b>	SIG	Reliability is divided into 8 levels, respectively indicated by 0x01-0x08. When the reliability level is 7 or 8, it means data is reliable. When the reliability level is another value, the data of this frame is not recommended.
<b>Byte6</b>	Reserved Bit	Reserved Bit
<b>Byte7</b>	Reserved Bit	Reserved Bit

### 10. Interface Description of Serial Port Upper Computer

Currently, the upper computer only supports Windows® operating systems, applicable to TF series products by Benewake (Beijing) Co. Ltd. In addition, it is limited to the product with serial communication protocols output. For detailed operations, please see the following description.

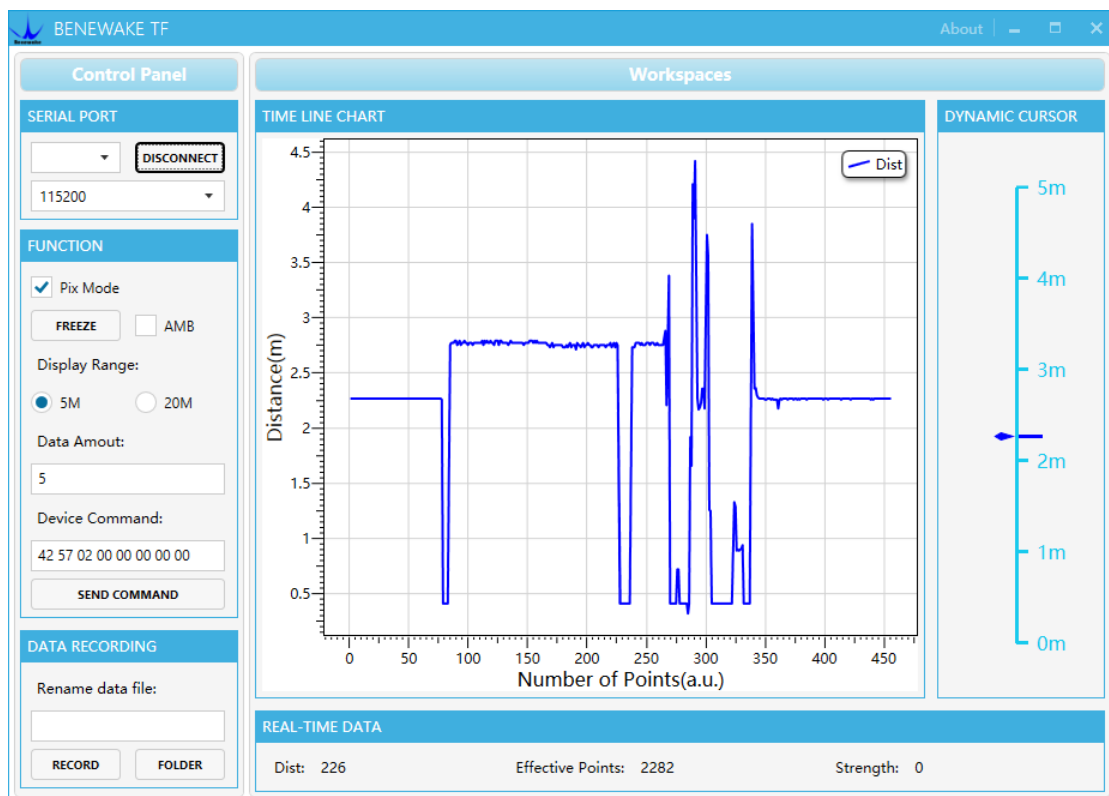

Client Interface of Distance Measurement Demonstration in Windows

TF series LiDAR connects with computer through TTL-USB adapter plate. Windows installs the driver by default. If the installation fails, please contact the technical support of our company.

- Serial Port: select the corresponding port number for LiDAR. Baud rate is 115200 by default. Click the **【CONNECT】** button to connect with LiDAR. If the LiDAR is standard serial port version, the TIME LINE CHART in the working area will display the data graph updated by LiDAR in real-time. The x axis is the quantity identification for received data and the y axis is the distance value output by LiDAR (unit: m);



- **FUNCTION:** if the product is Pixhawk, it is needed to click the box in front of pix mode. FREEZE can freeze the TIME LINE CHART in the working area for better observation. Display Rang can select the range of 5m or 20 m. Meanwhile, the scaleplate in the Dynamic cursor area can automatically change. Data amout is the data mean filtering and it is displayed by default after 5 groups of data averaging. After modifying the value, press the Enter key to modify the length of mean data value. Device Command can send hexadecimal port command to modify or set functions. For now, TF02 is not available for this operation.
- **DATA RECORDING:** the name of the data file can be modified and saved in the text box. Click **【RECORD】** to start saving data, and click again to stop saving. Click the **【FOLDER】** button to open the folder of data files.
- **REAL-TIME DATA:** the real-time data area can display LiDAR data in real time. Among them, Dist stands for distance measurement value with cm as unit. Effective Points indicate the total quantity of effective data output by LiDAR. Strength represents the intensity of signal. On pix mode, for the reason of no strength information, the Strength is 0 by default.



**Application Notice:**

- The product is a custom-made precision optical instrument and must be maintained by engineers of our company.
- Operating temperature:  $-10^{\circ}\text{C}$ - $60^{\circ}\text{C}$ .
- Storage temperature:  $-20^{\circ}\text{C}$  - $80^{\circ}\text{C}$ .
- This product adopts a special optical system. Please do not use the product under the sun for a long time, and storage away from light.

