

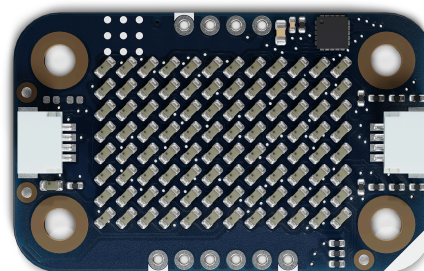

User Manual  
SKU: ABX00152



## Description

The Arduino Modulino LED Matrix features an 8×12 LED matrix (96 blue LEDs total) controlled by an on-board STM32C011F4U6TR microcontroller using charlieplexing technology. This display module provides LED matrix functionality for enabling text, graphics, animations, and visual feedback for a wide range of interactive projects.

## Target Areas

Maker, beginner, education

---



# Contents

<b>1 Application Examples</b>	<b>3</b>
<b>2 Features</b>	<b>4</b>
2.1 Contents	4
<b>3 Related Products</b>	<b>4</b>
<b>4 Rating</b>	<b>4</b>
4.1 Recommended Operating Conditions	4
<b>5 Power Tree</b>	<b>5</b>
<b>6 Block Diagram</b>	<b>5</b>
<b>7 Functional Overview</b>	<b>6</b>
7.1 Technical Specifications (Module-Specific)	6
7.2 Pinout	7
7.3 Power Specifications	9
7.4 Mechanical Information	9
7.5 I2C Address Reference	10
7.5.1 Pull-up Resistors	12
<b>8 Device Operation</b>	<b>12</b>
8.1 Getting Started	12
<b>9 Certifications Summary</b>	<b>13</b>
<b>10 Declaration of Conformity CE DoC (EU)</b>	<b>13</b>
<b>11 Declaration of Conformity to EU RoHS &amp; REACH 211 01/19/2021</b>	
<b>12 FCC WARNING</b>	<b>14</b>
<b>13 IC Caution</b>	<b>14</b>
<b>14 Conflict Minerals Declaration</b>	<b>14</b>



## 1 Application Examples

- **Text and Graphics Display** Show scrolling text, numbers, symbols, or simple graphics for status displays, counters, or informational interfaces.
- **Visual Notifications** Create eye-catching alerts, progress bars, or status indicators for IoT projects, alarms, or system monitoring applications.
- **Interactive Art and Games** Design animated displays, simple games, or artistic patterns with programmable LED matrix effects and real-time graphics.



## 2 Features

- **8×12 LED matrix** (96 blue LEDs total) providing versatile display capabilities.
- **Charlieplexing control** using 11 microcontroller pins for efficient LED driving.
- Integrated **STM32C011F4U6TR** microcontroller providing I2C interface.
- Designed for **3.3V** operation via the Qwiic connector (I2C).

### 2.1 Contents

SKU	Name	Purpose	Quantity
ABX00152	Modulino LED Matrix	8×12 programmable LED display	1
	I2C Qwiic cable	Compatible with the Qwiic standard	1

## 3 Related Products

- *SKU: ASX00027* - Arduino® Sensor Kit
- *SKU: K000007* - Arduino® Starter Kit
- *SKU: AKX00026* - Arduino® Oplà IoT Kit
- *SKU: AKX00069* - Arduino® Plug and Make Kit

## 4 Rating

### 4.1 Recommended Operating Conditions

- **Powered at 3.3 V** through the Qwiic interface (in accordance with the Qwiic standard)
- **Operating temperature:** -40 °C to +85 °C

#### Typical current consumption:

- Microcontroller: ~3.4 mA
- LED matrix: Variable based on number of active LEDs (up to ~200 mA peak)

## 5 Power Tree

The power tree for the Modulino LED Matrix can be consulted below:

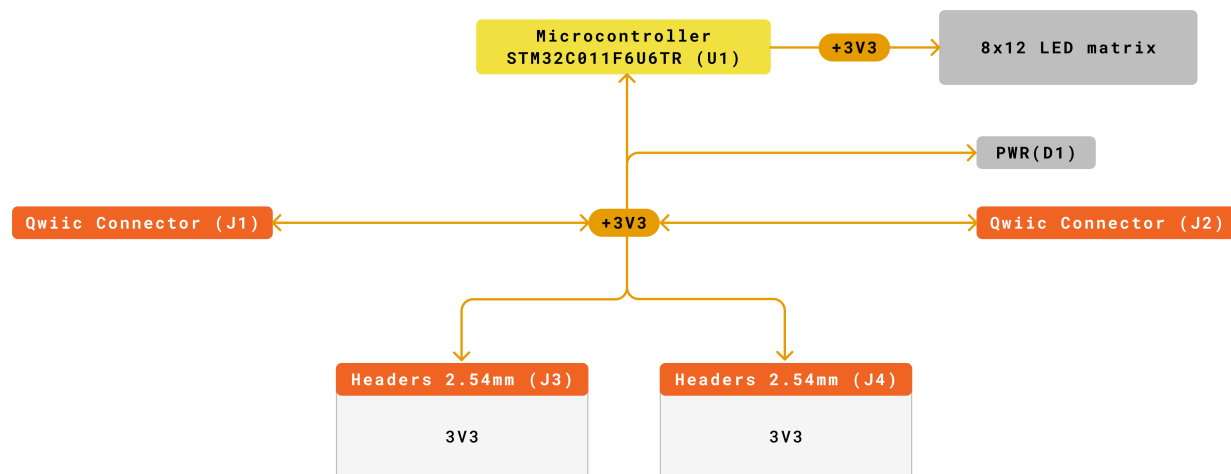

<b>Legend:</b>	Connector	+3V3
VIN	Main Part	+5V
VBUS	Internal Part	

Modulino Matrix  
SKU code: ASX0152  
Power Tree  
Last update: 24 Set, 2025

Modulino LED Matrix Power Tree

## 6 Block Diagram

This node includes an STM32C011F4U6TR microcontroller that drives an 8x12 LED matrix using charlieplexing with 11 GPIO pins. It communicates via I2C by default, but can be reprogrammed via SWD for custom display functions.

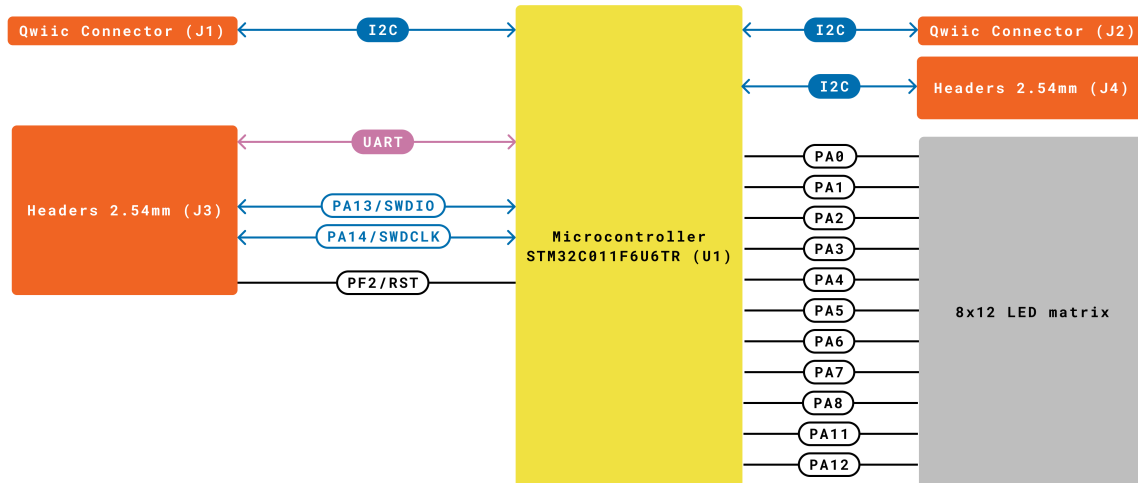

Modulino LED Matrix Block Diagram

## 7 Functional Overview

The Modulino LED Matrix uses charlieplexing technology to control 96 blue LEDs (LTST-C191TBK) with only 11 microcontroller pins (PA0-PA8, PA11, PA12). This efficient multiplexing technique allows individual LED control whilst minimising pin usage. The STM32C011F4U6TR manages the complex timing required for charlieplexing and provides simple I2C commands for drawing text, graphics, and animations.

### 7.1 Technical Specifications (Module-Specific)

Specification	Details
Microcontroller	STM32C011F4U6TR
LED Matrix	8×12 LEDs (96 total)
LED Color	Blue
LED Part Number	LTST-C191TBK
Control Method	Charlieplexing with 11 pins
Supply Voltage	3.3 V
Power Consumption	~3.4 mA (MCU) + variable (LEDs, up to 200 mA)
Display Resolution	8 rows × 12 columns

## 7.2 Pinout

### Qwiic / I2C (1×4 Solderable Pads)

Pin	Function
GND	Ground
3.3 V	Power Supply (3.3 V)
SDA	I2C Data
SCL	I2C Clock

These solderable pads and the Qwiic connectors share the same I2C bus at 3.3 V.

**Note:** The 1×4 header is not mounted by default; only the solderable pads are provided for custom wiring solutions.

### Additional 1×6 Header (Debug & Power)

Pin	Function
GND	Ground
3V3	3.3 V Power
PF2	RESET (NRST)
SWCLK	SWD Clock (PA14)
SWDIO	SWD Data (PA13)
GND	Ground

**Note:** The LED matrix is controlled by pins PA0, PA1, PA2, PA3, PA4, PA5, PA6, PA7, PA8, PA11, and PA12 using charlieplexing. Due to space constraints on the specialised PCB, only the RESET strap is populated.

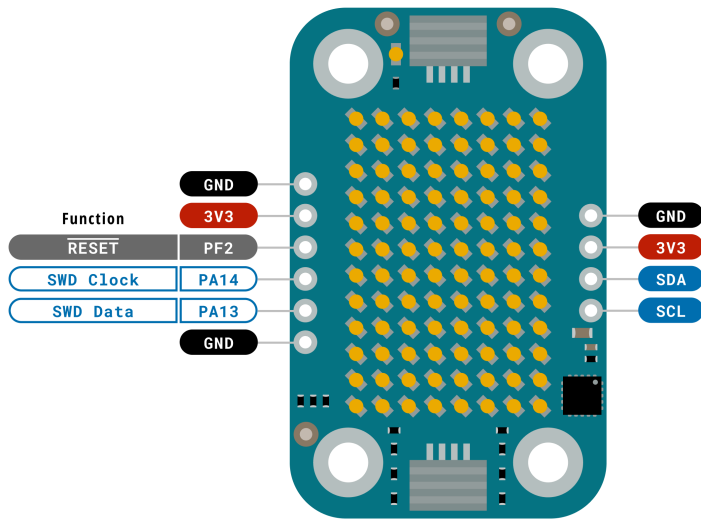

<b>Legend:</b>	Digital	I2C	Other SERIAL	 <b>ARDUINO</b> Modulino LED Matrix SKU code: ABX00152 Pinout Last update: 27 Mar, 2026
Power	Analog	SPI	Analog	
Ground	Main Part	UART/USART	PWM/Timer	

Pinout Overview

### 7.3 Power Specifications

- **Nominal operating voltage:** 3.3 V via Qwiic
- **LED matrix current:** Variable, up to 200 mA peak

### 7.4 Mechanical Information

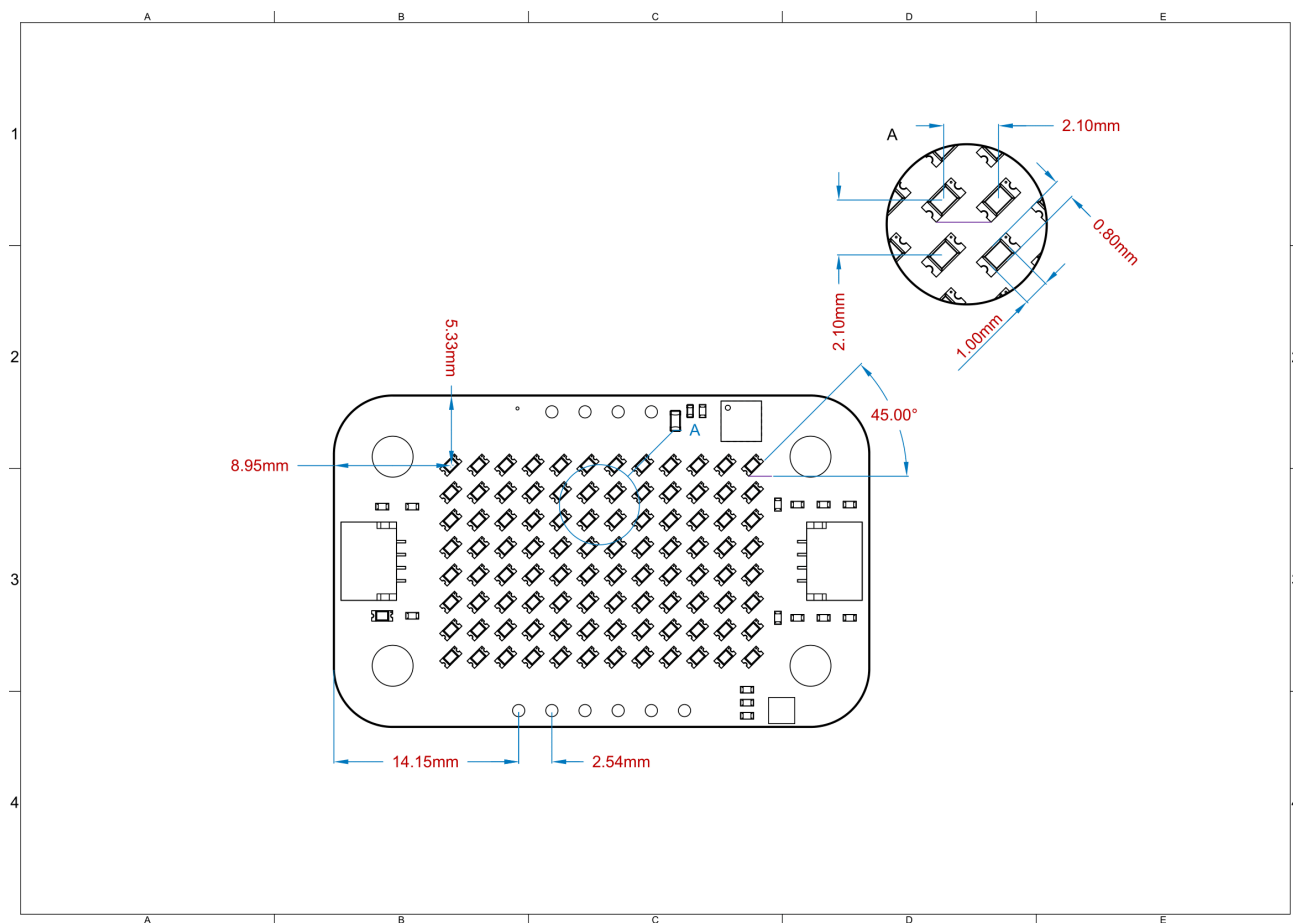

Modulino LED Matrix Mechanical Information

- Board dimensions: 41 mm × 25.36 mm
- Thickness: 1.6 mm ( $\pm 0.2$  mm)
- Four mounting holes ( $\varnothing$  3.2 mm)
  - Hole spacing: 16 mm vertically, 32 mm horizontally

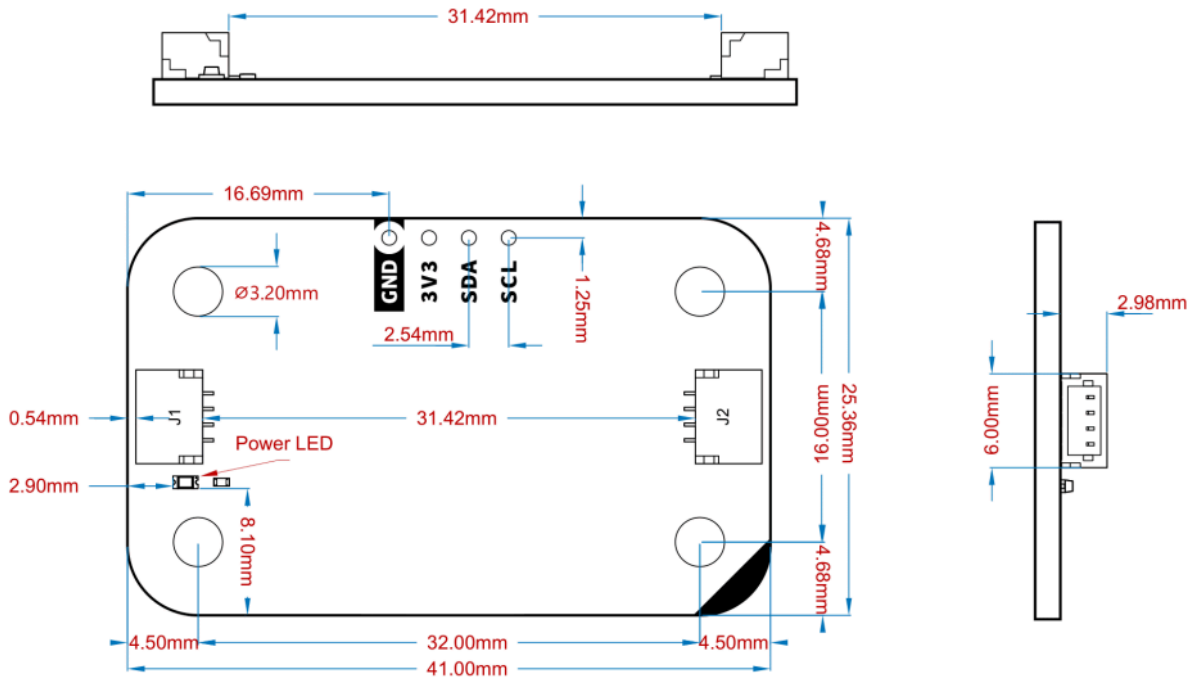

Modulino Node Shape

## 7.5 I2C Address Reference

Board Silk Name	Sensor/Actuator	Modulino I2C Address (HEX)	Editable Addresses (HEX)	Hardware I2C Address (HEX)
MODULINO LED MATRIX	8×12 LED Matrix	0x32	Any custom address (via software config.)	0x19

### Note:

- Default I2C address is **0x32**.
- A white rectangle on the bottom silk allows users to write a new address after reconfiguration.

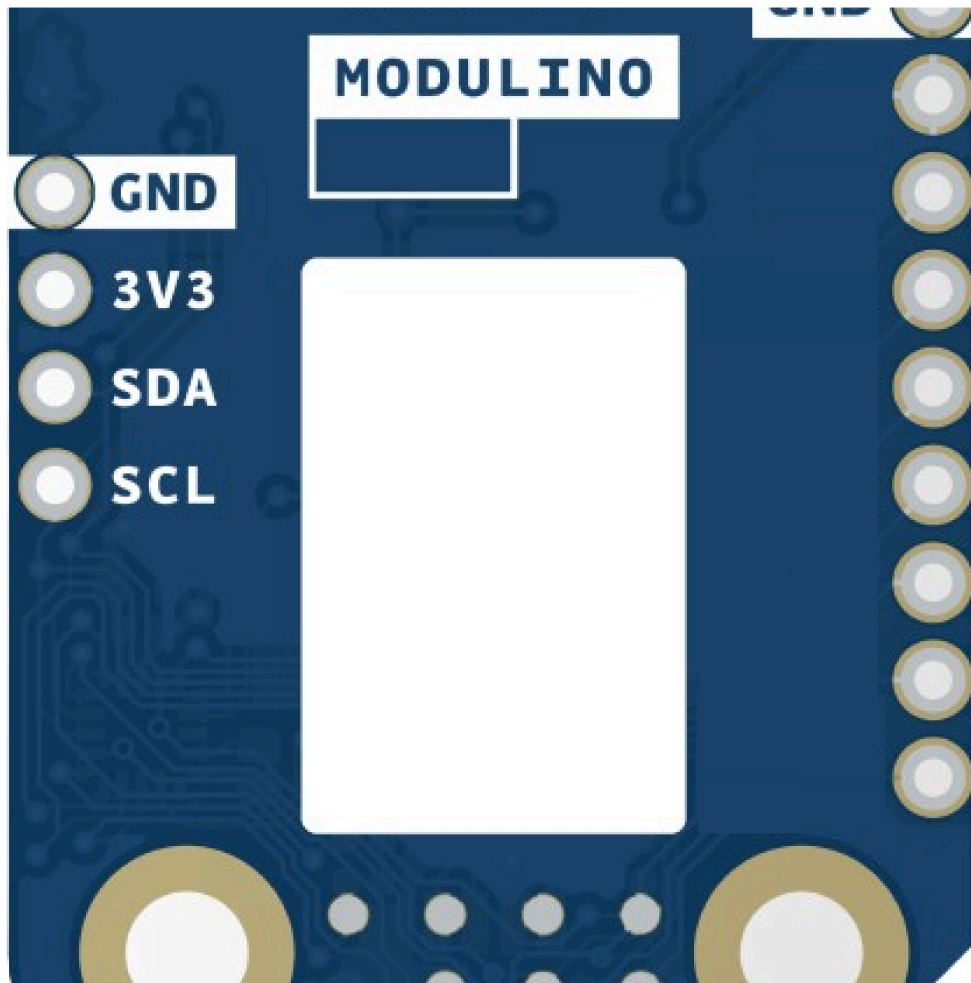

*Blank silk for identification*

### 7.5.1 Pull-up Resistors

This module has pads for optional I2C pull-up mounting in both data lines. No resistors are mounted by default but in case the resistors are needed 4.7 K resistors in an SMD 0402 format are recommended.

These are positioned near the Qwiic connector on the power LED side.

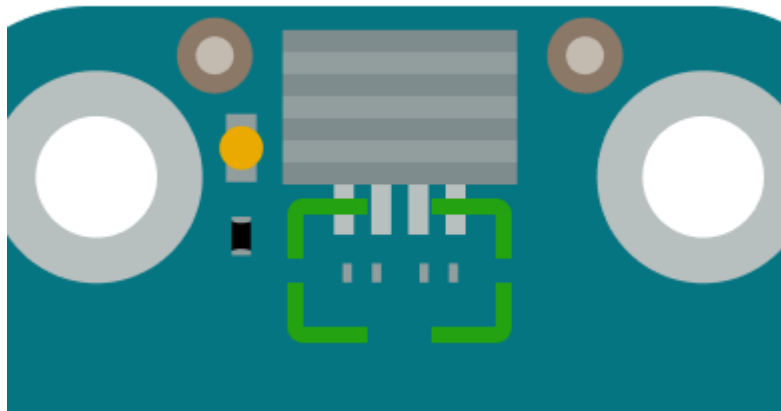

*Generic pull-up resistor position*

## 8 Device Operation

By default, the board is an I2C target device that manages the complex charlieplexing required to control the 8×12 LED matrix. The STM32C011F4U6TR handles all timing-critical operations whilst providing simple I2C commands for drawing pixels, text, and graphics. The matrix provides the same dimensions as the Arduino® UNO R4 WiFi LED matrix (but with blue LEDs instead of red), ensuring code compatibility.

### 8.1 Getting Started

Use any standard Arduino workflow-desktop IDE or Arduino Cloud Editor. The official Modulino library provides comprehensive graphics functions compatible with Arduino® UNO R4 WiFi matrix code. Power considerations should account for LED matrix current draw when multiple LEDs are illuminated simultaneously.

# Certifications

## 9 Certifications Summary

Certification	Status
CE/RED (Europe)	Yes
UKCA (UK)	Yes
FCC (USA)	Yes
IC (Canada)	Yes
RoHS	Yes
REACH	Yes
WEEE	Yes

## 10 Declaration of Conformity CE DoC (EU)

We declare under our sole responsibility that the products above are in conformity with the essential requirements of the following EU Directives and therefore qualify for free movement within markets comprising the European Union (EU) and European Economic Area (EEA).

## 11 Declaration of Conformity to EU RoHS & REACH 211 01/19/2021

Arduino boards are in compliance with RoHS 2 Directive 2011/65/EU of the European Parliament and RoHS 3 Directive 2015/863/EU of the Council of 4 June 2015 on the restriction of the use of certain hazardous substances in electrical and electronic equipment.

Substance	Maximum limit (ppm)
Lead (Pb)	1000
Cadmium (Cd)	100
Mercury (Hg)	1000
Hexavalent Chromium (Cr6+)	1000
Poly Brominated Biphenyls (PBB)	1000
Poly Brominated Diphenyl ethers (PBDE)	1000
Bis(2-Ethylhexyl) phthalate (DEHP)	1000
Benzyl butyl phthalate (BBP)	1000
Dibutyl phthalate (DBP)	1000
Diisobutyl phthalate (DIBP)	1000

Exemptions: No exemptions are claimed.

Arduino Boards are fully compliant with the related requirements of European Union Regulation (EC) 1907 /2006 concerning the Registration, Evaluation, Authorization and Restriction of Chemicals (REACH). We declare none of the SVHCs (<https://echa.europa.eu/web/guest/candidate-list-table>), the Candidate List of Substances of Very High



Concern for authorization currently released by ECHA, is present in all products (and also package) in quantities totaling in a concentration equal or above 0.1%. To the best of our knowledge, we also declare that our products do not contain any of the substances listed on the "Authorization List" (Annex XIV of the REACH regulations) and Substances of Very High Concern (SVHC) in any significant amounts as specified by the Annex XVII of Candidate list published by ECHA (European Chemical Agency) 1907 /2006/EC.

## 12 FCC WARNING

This device complies with part 15 of the FCC Rules.

Operation is subject to the following two conditions:

(1) This device may not cause harmful interference, and (2) this device must accept any interference received, including interference that may cause undesired operation.

## 13 IC Caution

This device complies with Industry Canada licence-exempt RSS standard(s).

Operation is subject to the following two conditions:

(1) This device may not cause interference, and (2) this device must accept any interference, including interference that may cause undesired operation of the device.

## 14 Conflict Minerals Declaration

As a global supplier of electronic and electrical components, Arduino is aware of our obligations with regard to laws and regulations regarding Conflict Minerals, specifically the Dodd-Frank Wall Street Reform and Consumer Protection Act, Section 1502. Arduino does not directly source or process conflict minerals such as Tin, Tantalum, Tungsten, or Gold. Conflict minerals are contained in our products in the form of solder or as a component in metal alloys. As part of our reasonable due diligence, Arduino has contacted component suppliers within our supply chain to verify their continued compliance with the regulations. Based on the information received thus far we declare that our products contain Conflict Minerals sourced from conflict-free areas.



## Company Information

<b>Company name</b>	<b>Arduino SRL</b>
Company Address	Via Andrea Appiani, 25 - 20900 MONZA (Italy)

## Reference Documentation

Ref	Link
Arduino IDE (Desktop)	<a href="https://www.arduino.cc/en/software/">https://www.arduino.cc/en/software/</a>
Arduino Courses	<a href="https://www.arduino.cc/education/courses">https://www.arduino.cc/education/courses</a>
Arduino Documentation	<a href="https://docs.arduino.cc/">https://docs.arduino.cc/</a>
Arduino IDE (Cloud)	<a href="https://create.arduino.cc/editor">https://create.arduino.cc/editor</a>
Cloud IDE Getting Started	<a href="https://docs.arduino.cc/cloud/web-editor/tutorials/getting-started/getting-started-web-editor">https://docs.arduino.cc/cloud/web-editor/tutorials/getting-started/getting-started-web-editor</a>
Project Hub	<a href="https://projecthub.arduino.cc/">https://projecthub.arduino.cc/</a>
Library Reference	<a href="https://github.com/arduino-libraries/">https://github.com/arduino-libraries/</a>
Online Store	<a href="https://store.arduino.cc/">https://store.arduino.cc/</a>

## Revision History

Date	Revision	Changes
27/03/2026	1	First release