

Description

The Arduino Modulino® Light features the LTR-381RGB-01 ambient light, RGB, and infrared sensor, providing comprehensive optical sensing capabilities in a compact form factor. This sensor enables colour recognition, ambient light measurement, and infrared detection for a wide range of interactive and automation applications.

Target Areas

Maker, beginner, education



Contents

1 Application Examples	3
2 Features	4
2.1 Contents	4
3 Related Products	4
4 Rating	4
4.1 Recommended Operating Conditions	4
5 Power Tree	5
6 Block Diagram	5
7 Functional Overview	6
7.1 Technical Specifications	6
7.2 Pinout	7
7.3 Power Specifications	9
7.4 Mechanical Information	9
7.5 Mechanical Information	9
7.6 I2C Address Reference	10
8 Device Operation	11
8.1 Getting Started	11
9 Certifications Summary	11
10 Declaration of Conformity CE DoC (EU)	11
11 Declaration of Conformity to EU RoHS & REACH 211 01/19/2021	
12 FCC WARNING	13
13 IC Caution	13
14 Conflict Minerals Declaration	13



1 Application Examples

- **Colour Recognition** Detect and identify colours in objects, liquids, or environments for sorting systems, art projects, or interactive installations.
- **Ambient Light Control** Automatically adjust LED brightness, screen intensity, or activate lighting systems based on surrounding light conditions for smart home applications.
- **Infrared Detection** Monitor infrared radiation for proximity sensing, temperature indication, or remote control applications in various IoT projects.



2 Features

- **LTR-381RGB-01 sensor** providing ambient light, RGB colour, and infrared measurements.
- **High-precision colour detection** with separate red, green, and blue channels for accurate colour identification.
- **Ambient light sensing** with wide dynamic range for automatic lighting control.
- **Infrared detection** for proximity and thermal sensing applications.
- **I2C (Qwiic)** interface for solder-free integration; operates at **3.3V**.

2.1 Contents

SKU	Name	Purpose	Quantity
ABX00111	Modulino® Light	Ambient light, RGB and infrared sensor	1
	I2C Qwiic cable	Compatible with the Qwiic standard	1

3 Related Products

- *SKU: ASX00027* - Arduino® Sensor Kit
- *SKU: K000007* - Arduino® Starter Kit
- *SKU: AKX00026* - Arduino® Oplà IoT Kit
- *SKU: AKX00069* - Arduino® Plug and Make Kit

4 Rating

4.1 Recommended Operating Conditions

- **Powered at 3.3 V** through the Qwiic interface (in accordance with the Qwiic standard)
- **Operating temperature:** -30 °C to +70 °C

Typical current consumption:

- ~200 µA active measurement

5 Power Tree

The power tree for the Modulino® Light can be consulted below:

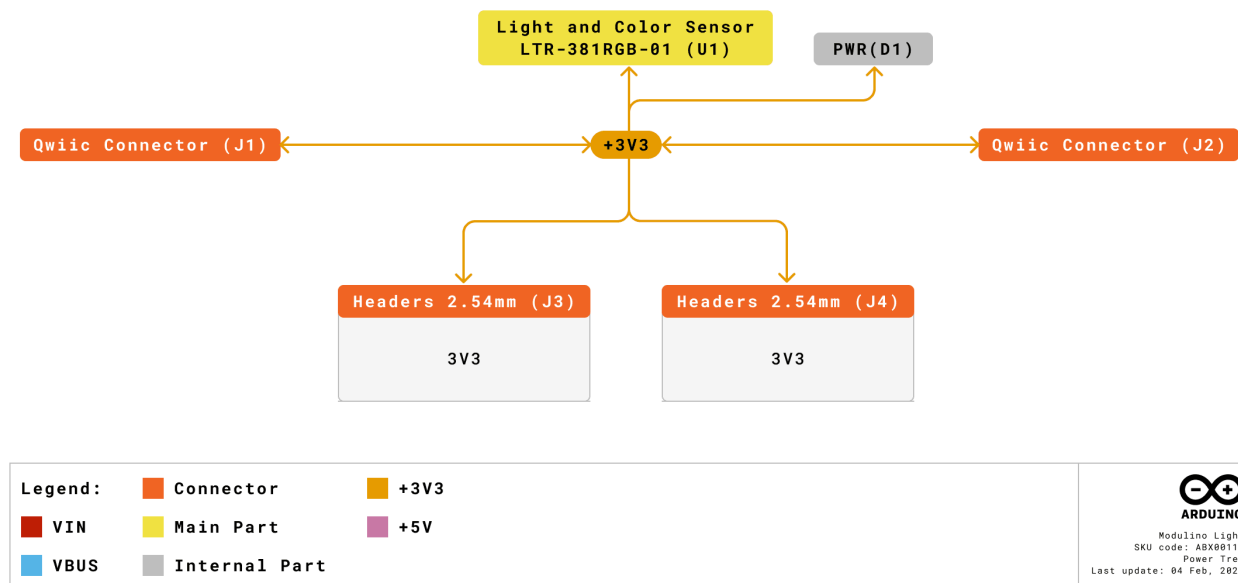

Modulino® Light Power Tree

6 Block Diagram

This node is designed to be placed on an I2C bus, allowing the on-board LTR-381RGB-01 sensor to communicate with a host microcontroller via I2C.

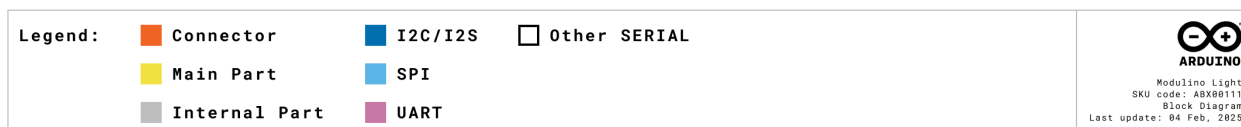
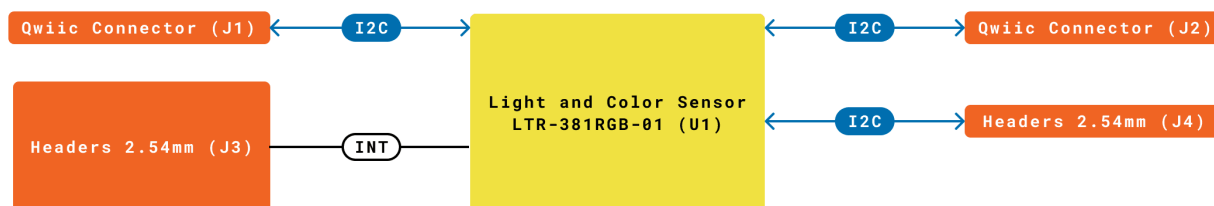

Modulino® Light block diagram

7 Functional Overview

The Modulino® Light uses the LTR-381RGB-01 sensor to measure ambient light levels, detect RGB colour components, and sense infrared radiation. The sensor communicates via I2C (through the Qwiic connector at 3.3V) and provides an interrupt output for event-driven applications. The sensor can distinguish between different light sources and accurately measure colour characteristics.

7.1 Technical Specifications

Specification	Details
Sensor	LTR-381RGB-01
Supply Voltage	Rec:3.3 V
Power Consumption	~200 µA active
Ambient Light Range	0.01 lux to 120,000 lux
Spectral Response	Red: 600-700 nm, Green: 500-600 nm, Blue: 400-500 nm
Resolution	20-bit ADC
Communication	I2C

7.2 Pinout

Qwiic / I2C (1×4 Header)

Pin	Function
GND	Ground
3.3 V	Power Supply (3.3 V)
SDA	I2C Data
SCL	I2C Clock

These pads and the Qwiic connectors share the same I2C bus. You can optionally solder header pins here.

Additional 1×4 Header (LTR-381RGB-01 Signals)

Pin	Function
GND	Ground
GND	Ground
3V3	3.3 V Power
INT	Interrupt Output

Note: INT pin features a 10 k Ω pull-up resistor to 3.3 V and provides interrupt signalling for threshold detection and data ready events.

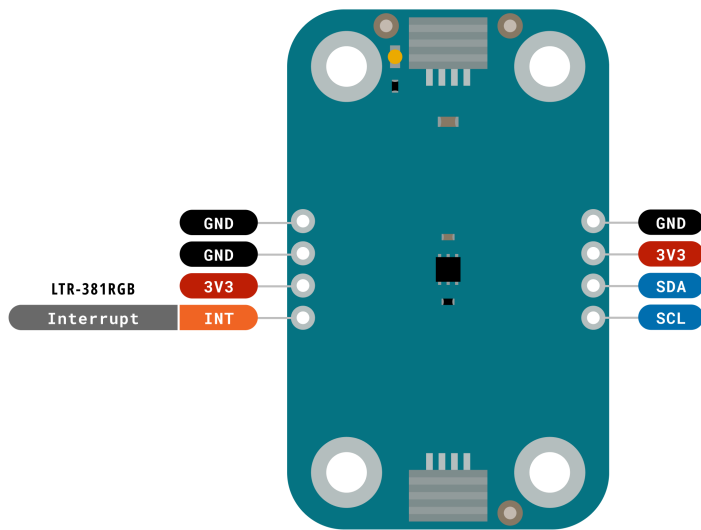

Legend:	Digital	I2C	Other SERIAL
Power	Analog	SPI	Analog
Ground	Main Part	UART/USART	PWM/Timer

Modulino Light
SKU code: ABX00111
Pinout
Last update: 12 Sep, 2025

Pinout Overview

7.3 Power Specifications

- **Nominal operating voltage:** 3.3 V via Qwiic

7.4 Mechanical Information

7.5 Mechanical Information

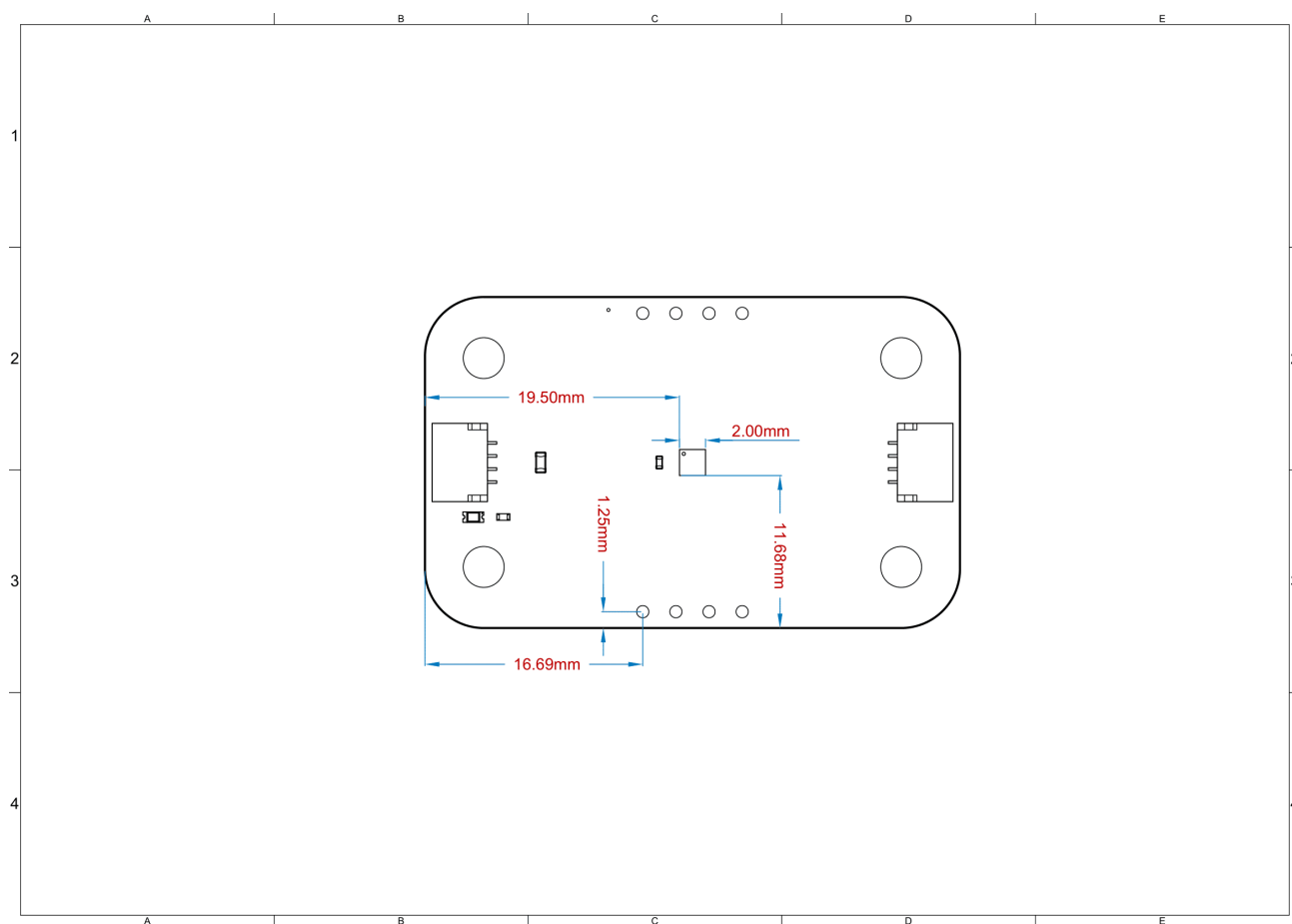

Modulino® Light Mechanical Information

- Board dimensions: 41 mm × 25.36 mm
- Thickness: 1.6 mm (±0.2 mm)
- Four mounting holes (∅ 3.2 mm)
 - Hole spacing: 16 mm vertically, 32 mm horizontally

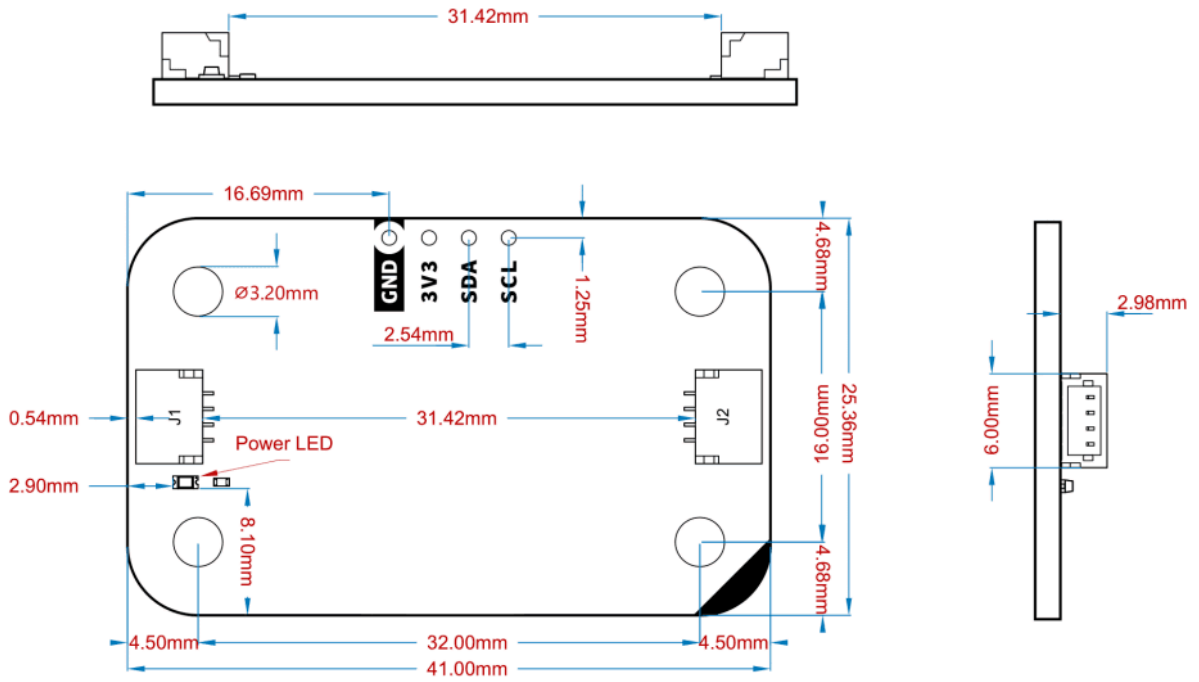

Modugno® Node Shape

7.6 I2C Address Reference

Board Silk Name	Sensor	Modugno® I2C Address (HEX)	Editable Addresses (HEX)	Hardware I2C Address (HEX)
MODULINO LIGHT	LTR-381RGB-01	0x53	Fixed hardware address	0x53

Note: The default and only address is **0x53**. This sensor has a fixed I2C address that cannot be changed.



8 Device Operation

The Modulino® Light operates as an I2C target device on the Qwiic bus. A host microcontroller can read ambient light values, RGB colour components, and infrared levels. The INT pin can be configured to trigger interrupts when measurements exceed programmed thresholds.

8.1 Getting Started

Use any standard Arduino or microcontroller environment at 3.3 V. The `Arduino_LTR381RGB` library provides comprehensive functions for colour detection, ambient light measurement, and infrared sensing. The sensor should be positioned to face the light source or object being measured, with the sensing area unobstructed.

Certifications

9 Certifications Summary

Certification	Status
CE/RED (Europe)	Yes
UKCA (UK)	Yes
FCC (USA)	Yes
IC (Canada)	Yes
RoHS	Yes
REACH	Yes
WEEE	Yes

10 Declaration of Conformity CE DoC (EU)

We declare under our sole responsibility that the products above are in conformity with the essential requirements of the following EU Directives and therefore qualify for free movement within markets comprising the European Union (EU) and European Economic Area (EEA).



11 Declaration of Conformity to EU RoHS & REACH 211 01/19/2021

Arduino boards are in compliance with RoHS 2 Directive 2011/65/EU of the European Parliament and RoHS 3 Directive 2015/863/EU of the Council of 4 June 2015 on the restriction of the use of certain hazardous substances in electrical and electronic equipment.

Substance	Maximum limit (ppm)
Lead (Pb)	1000
Cadmium (Cd)	100
Mercury (Hg)	1000
Hexavalent Chromium (Cr6+)	1000
Poly Brominated Biphenyls (PBB)	1000
Poly Brominated Diphenyl ethers (PBDE)	1000
Bis(2-Ethylhexyl) phthalate (DEHP)	1000
Benzyl butyl phthalate (BBP)	1000
Dibutyl phthalate (DBP)	1000
Diisobutyl phthalate (DIBP)	1000

Exemptions: No exemptions are claimed.

Arduino Boards are fully compliant with the related requirements of European Union Regulation (EC) 1907 /2006 concerning the Registration, Evaluation, Authorization and Restriction of Chemicals (REACH). We declare none of the SVHCs (<https://echa.europa.eu/web/guest/candidate-list-table>), the Candidate List of Substances of Very High Concern for authorization currently released by ECHA, is present in all products (and also package) in quantities totaling in a concentration equal or above 0.1%. To the best of our knowledge, we also declare that our products do not contain any of the substances listed on the "Authorization List" (Annex XIV of the REACH regulations) and Substances of Very High Concern (SVHC) in any significant amounts as specified by the Annex XVII of Candidate list published by ECHA (European Chemical Agency) 1907 /2006/EC.



12 FCC WARNING

This device complies with part 15 of the FCC Rules.

Operation is subject to the following two conditions:

(1) This device may not cause harmful interference, and (2) this device must accept any interference received, including interference that may cause undesired operation.

13 IC Caution

This device complies with Industry Canada licence-exempt RSS standard(s).

Operation is subject to the following two conditions:

(1) This device may not cause interference, and (2) this device must accept any interference, including interference that may cause undesired operation of the device.

14 Conflict Minerals Declaration

As a global supplier of electronic and electrical components, Arduino is aware of our obligations with regard to laws and regulations regarding Conflict Minerals, specifically the Dodd-Frank Wall Street Reform and Consumer Protection Act, Section 1502. Arduino does not directly source or process conflict minerals such as Tin, Tantalum, Tungsten, or Gold. Conflict minerals are contained in our products in the form of solder or as a component in metal alloys. As part of our reasonable due diligence, Arduino has contacted component suppliers within our supply chain to verify their continued compliance with the regulations. Based on the information received thus far we declare that our products contain Conflict Minerals sourced from conflict-free areas.

Company Information

Company name	Arduino SRL
Company Address	Via Andrea Appiani, 25 - 20900 MONZA (Italy)



Reference Documentation

Ref	Link
Arduino IDE (Desktop)	https://www.arduino.cc/en/software/
Arduino Courses	https://www.arduino.cc/education/courses
Arduino Documentation	https://docs.arduino.cc/
Arduino IDE (Cloud)	https://create.arduino.cc/editor
Cloud IDE Getting Started	https://docs.arduino.cc/cloud/web-editor/tutorials/getting-started/getting-started-web-editor
Project Hub	https://projecthub.arduino.cc/
Library Reference	https://github.com/arduino-libraries/
Online Store	https://store.arduino.cc/

Revision History

Date	Revision	Changes
14/10/2025	1	First release